

# Dynamic Performance of Doubly Fed Induction Generator-Based Wind Turbines during Grid Faults

Bibhu Prasad Nanda

SYNERGY Institute of Technology, BBSR, Odisha, India  
 bibhunanda1986@yahoo.com

**Abstract** – The wound rotor doubly fed electric machine is the only electric machine that operates with rated torque to twice synchronous speed for a given frequency of excitation. In order to evaluate the advantages of this new control proposal, namely VOC-RRF, their performance will may be compared with the response obtained with a classical VOC algorithm by means of PSCAD/EMTDC simulation models. According to grid codes issued by utilities, tripping of wind turbines following grid faults is not allowed. Besides, to provide voltage support to the grid mandatory reactive current supply is necessary. To enable wind turbines ride-through low voltage periods special protection measures have to be implemented. In this paper the behavior of DFIG based wind turbines during grid faults is discussed and elucidated using simulation results. It is shown that with properly designed crowbar and DC-link chopper even zero voltage ride-through is possible.

**Keywords** — Wind Turbine, Doubly-Fed Induction Generator, Fault-Ride Through.

## I. INTRODUCTION

In many countries in the world energy policies are focused on the increased utilization of wind energy due to the fact that wind power can provide a considerable input to electricity production. Besides, wind represents a natural resource which is renewable, environmentally benign and is available nearly in every country. In Germany the installed wind turbine capacity already reached 19 GW. By the year 2020 a total wind power capacity of nearly 50 GW is expected, which is more than 50% of the German peak load.

It is obvious that for secure power system operation wind turbines have to meet grid requirements. For guaranteeing grid compliance utilities established Grid Codes [1]-[2] that represent fundamental guidelines for wind turbine manufacturers and wind farm planners. The basic requirements comprise fault ride-through (FRT) capability and contribution to grid voltage control during emergency situations.

In this paper the authors will discuss the dynamic behaviour of wind turbines based on doubly fed induction generators (DFIG) which is currently the most popular technology in this field. The main advantage of using DFIG results from the fact that only 30% of the power passes through the converter that is, therefore, smaller and cheaper compared with a full-size one. During grid faults the DFIG experiences over currents which lead also to increasing DC-voltage on the converter side. To avoid damage some special measures are necessary which however should not contravene grid requirements. Therefore, understanding between power engineers and developers of wind turbine converters is one of the

prerequisites for mutually acceptable technical solutions. The paper is organized as follows: First the fundamental Grid Code requirements will be explained briefly. Then, the behaviour of the DFIG wind turbines following grid faults is explained. The objective is to demonstrate the expected stress on the wind turbine and the converter in the absence of any counter measures. After that FRT measures currently under consideration in large multi-megawatt wind turbines will be introduced, and their effectiveness demonstrated on the basis of simulation results.

## II. GRID REQUIREMENTS

In the past wind turbines were separated from the grid following grid faults. However, as of now, separation of wind turbines for voltage values below 80% of the nominal voltage would lead to loss of an undesirable portion of power generation. Therefore, utilities now require an FRT capability as specified in Fig. 1. Wind turbine must stay connected even when the voltage at the point of common connection (PCC) with the grid drops to zero. The 150-ms delay shown in the figure accounts for the normal operating time of protection relays. The red solid line in Fig. 1 marks the lower voltage boundary rather than any characteristic voltage behavior.

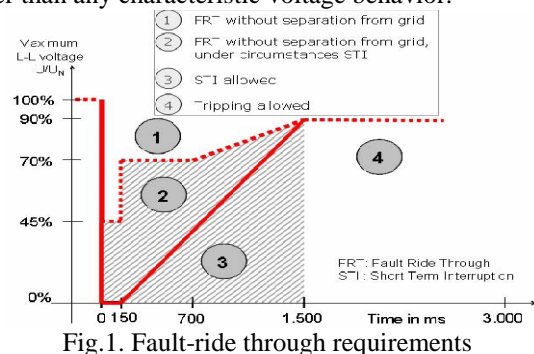

Fig.1. Fault-ride through requirements

According to the new E.on (one of the major utilities in Germany) grid code of 2006 [2] short term interruption (STI) is allowed under specific circumstances. STI in area 3 requires resynchronization within 2 s and a power increase rate of at least 10% of the nominal power per second. In area 2 the interruption time allowed is much less, just a few hundred milliseconds. Besides, reactive power supply by wind turbines is a requirement during this period. According to the German grid code wind turbines have to provide a mandatory voltage support during voltage dips. The corresponding voltage control characteristics are summarized in Fig 2. Accordingly wind turbines have to supply at least 1.0 p.u. reactive current already when the voltage falls below 50%. A dead band of

10% is introduced to avoid undesirable control actions. However, for wind farms connected to the high voltage grid continuous voltage control without dead band is also under consideration.

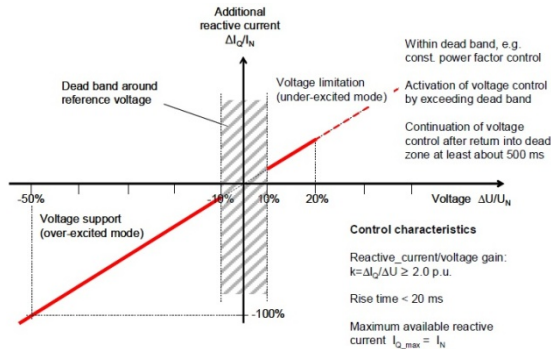

Fig. 2. Characteristic of wind turbine voltage control

### III. EFFECTS OF GRID FAULTS ON DFIG

#### A. Configuration of DFIG based Wind Turbines

The rotor of the DFIG is equipped with three phase windings, which are supplied via the rotor side slip rings by a voltage source converter (VSC) of variable frequency and magnitude (Fig. 3). Speed variability is ensured by the bi-directional transfer of slip power via the frequency converter.

(a) In the sub-synchronous operating mode (partial load range) the generator stator feeds all generated electrical power to the grid, and additionally makes slip power available which is fed from the frequency converter to the rotor.

(b) In the super-synchronous operating mode (nominal load range) on the other hand total power consists of the component from the generator stator plus slip power, which is fed from the rotor to the grid via the frequency converter. Active power, which is fed to the grid via the converter, amounts to roughly 25% of total power. The inverter rating is typically 25...30% of the total system power, while the speed range of the DFIG is +/- 30% around the synchronous speed. Lower inverter rating results in lower losses and thus higher overall efficiency, and lower costs for the inverter as well as for filters compared to a full-sized converter system.

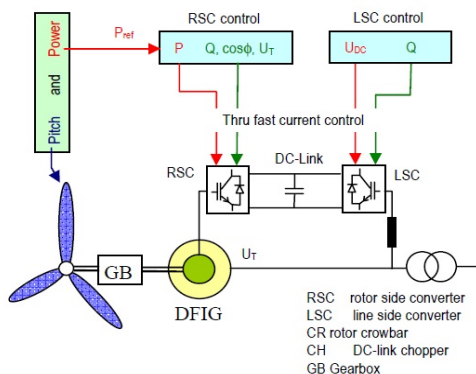

Fig.3. Structure of the DFIG based wind turbine

The control of the DFIG wind turbine embodies three parts:

- Speed control by controlling the electrical power reference provided to the converter as well as by the pitch angle.
- Rotor side converter (RSC) control directed at the control of active and reactive power on the stator side.
- Line side converter (LSC) control that keeps the DC link voltage constant and provides the additional opportunity to supply reactive power into the grid.

The RSC and LSC control is usually implemented together in the same converter control software whereas the speed/pitch control is realized as a separate unit. The converter enables decoupled active and reactive power control of the generator [3]-[10]. Moreover, reactive power control can be implemented at lower cost since the DFIG system basically operates in a similar manner to that of a synchronous generator as the excitation energy is provided by the converter. The control of active and reactive power is accomplished by the fast-dynamic control of the magnitude as well as the phase angle of the EMF supplied to the rotor. The superior dynamic performance of the DFIG results from the frequency converter which typically operates with sampling and switching frequencies of above 2kHz.

#### B. Effect of Three Phase Grid Short Circuits

To demonstrate the effect of a grid short-circuit a DFIG based wind turbine together with a small grid has been simulated using a detailed time domain model. This example is aimed to show the effects of a short-circuit without any countermeasures on the converter and generator side. As can be seen in Fig. 4 the grid fault can lead to considerable overcurrents and over-voltages putting the whole facility under stress. Conclusions deduced from the simulation results are summarized as follows:

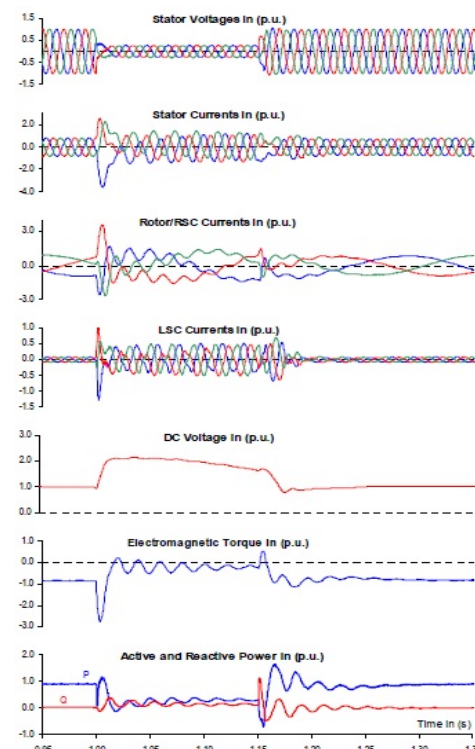

Fig.4. Behavior of DFIG wind turbine during a three phase grid short circuit without FRT measures (theoretical case)

\*As a consequence of the sudden short circuit the stator currents contain DC-components. On the rotor side these currents appear as AC, superposing the much slower steady-state rotor currents injected by the converter. Thus the nominal rotor current is exceeded more than 2-3 times, which obviously is not acceptable.

\* Higher rotor currents lead also to rising DC-link voltage. The DC-capacitor is usually not able to reduce this effect considerably so that the DC-voltage, without countermeasures, would reach values of about 2-3  $U_{DC\_nominal}$ , which are far away from capacitor specifications due to converter design.

\*Due to the common control, the LSC tries to stabilize the DC-voltage. This causes the LSC current to increase up to 50% of the wind turbine nominal current, which represents a significant overload of the LSC. Despite the action of the LSC, the DC-voltage will reach values mentioned above.

- Immediately after the short circuit clearance, the wind turbine shaft will experience oscillating torque, the first peak of which reaching 2-3  $t_{nominal}$  leading to severe stressing of the turbine shaft. As a general conclusion one can easily realize that without countermeasures grid short circuits would easily result in deterioration of the converter system. On the other hand, fast separation from the grid is not a favorable option since utilities expect voltage support during the fault and in its aftermath. Besides, the active power in feed should not be interrupted for a longer period of time. In the next chapter FRT control will be discussed in detail.

#### IV. FAULT-RIDE THROUGH WITH DFIG

Fig.5 shows a DFIG system for improved fault ride-through capability [11]. It contains two protection circuits, a DC-chopper and an AC-crowbar to avoid DC-link over-voltages during grid faults. The chopper module is not essential for fault ride-through operation but it increases the normal range of DFIG operation by smoothing the DC-link voltage during heavy imbalances of active power on the rotor-side and line-side converter. Theoretically converter and chopper could be designed to withstand even short-circuits at the stator terminals but economic considerations normally limit to a lower rating.

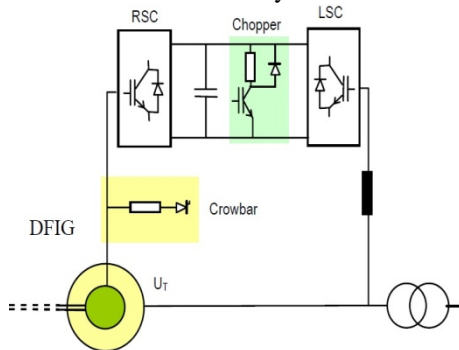

Fig.5. DFIG base system extended by FRT protection devices

Then, for deep voltage sags the crowbar short-circuits the rotor to protect the converter and the system goes to an asynchronous machine operating mode, in which the

DFIG is not controlled by the machine-side converter. The crowbar firing is triggered by the DC-voltage which rises due to the first rotor current peak. The IGBT's are usually stopped by the protection but the current and thus the energy continues to flow into the DC-link through the freewheeling diodes leading to a very fast voltage increase. When the crowbar is switched on, the converter is separated from the rotor circuits. The characteristic operating modes of the rotor side converter and the crowbar during FRT are shown in Fig. 6.

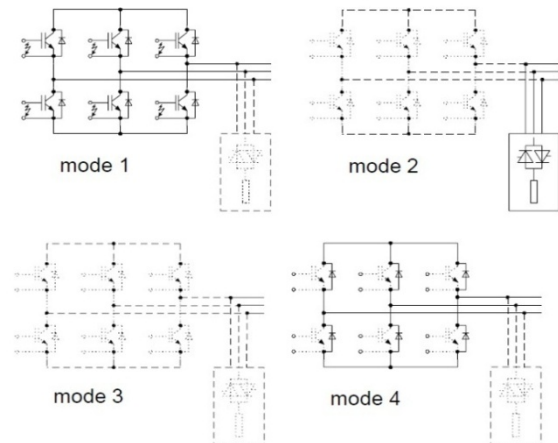

Fig.6. Operating modes of the DFIG rotor side converter

Following the short circuit the system goes first from normal mode 1 into mode 4. Then, mode 2 follows which is also called crowbar mode. After a short delay of about 60-120ms during which the flux transients in the machine die down, the converter resynchronizes and the system goes back into controlled DFIG operation. Because the crowbar thyristor switches used in many applications will not interrupt the current before their zero-crossing, the exact interruption time is not predictable. Therefore, between crowbar interruption and converter resynchronization is a possible time slot with open rotor circuits characterised as mode 3 in Fig.6. When the converter is started again the DFIG can provide reactive power support to the grid and thus help stabilizing the grid voltage. To avoid overload, active power will be reduced automatically when the converter current reaches its rated level. Additionally reactive power is dynamically provided by the line-side converter even during the period of crowbar firing. In Fig. 7 the characteristic behaviour of the DFIG is shown for the same fault as simulated for Fig. 4 but by considering crowbar and also the DC-link chopper immediately after the short circuit the DC-voltage rises to about the threshold value of 1.1 p.u., despite the intervention by the chopper. Then the crowbar is switched on and the RSC is separated from the DFIG. After 60 ms the RSC is re-synchronized and the wind turbine starts to supply active and reactive currents to the grid although the grid fault is still not cleared. To avoid overload, the rotor current limiter is active during this period. Following voltage recovery the system experiences a similar disturbance as at the beginning of the fault. However, in this case the DC-link voltage is kept within limit by the chopper so that the crowbar is not needed for a second time. As can be seen from the results the RSC has been

successfully protected against the overload during the grid fault. On the other hand, the short circuit currents in the stator and rotor circuits are not limited. Thus, the first peak in the electromagnetic torque is still high putting stress on the machine shaft. The whole system goes back to “normal” operation even if the grid voltage remains low. This operation mode requires also pitching of the rotor blades to adapt the generated power to the reduced active power supply that is now lower due to the current limitation. It is a matter of proper chopper design to avoid a second crowbar firing. Otherwise the second crowbar period would result in much higher reactive power consumption by the DFIG that is not desirable from the grid point of view. This case is shown in Fig. 8 for the same system fault as applied in the previous simulation examples. To demonstrate the effect of the second crowbar firing no chopper has been considered. As can be seen from the figure the reactive power consumption during this period reaches 1 p.u. that leads to considerable voltage excursion. In the worst case scenario, it may result in grid voltage collapse. Therefore, a second crowbar firing should be avoided in all possible cases. At even lower voltages down to 0% the IGBTs are switched off and the system remains in a standby mode, where the controller is still in operation and observes the grid voltages. Simulation results are shown in Fig. 9. If the voltages are above a certain threshold value, the DFIG system is very quickly synchronized and is back in operation again, otherwise the system shuts down after a preset time. This sequence of events leads to the conclusion that a minimum, physically reasonable voltage level should be defined in the grid code, above which reactive power support is demanded and below the standby mode preferred to expedite immediate system operation after voltage recovery.

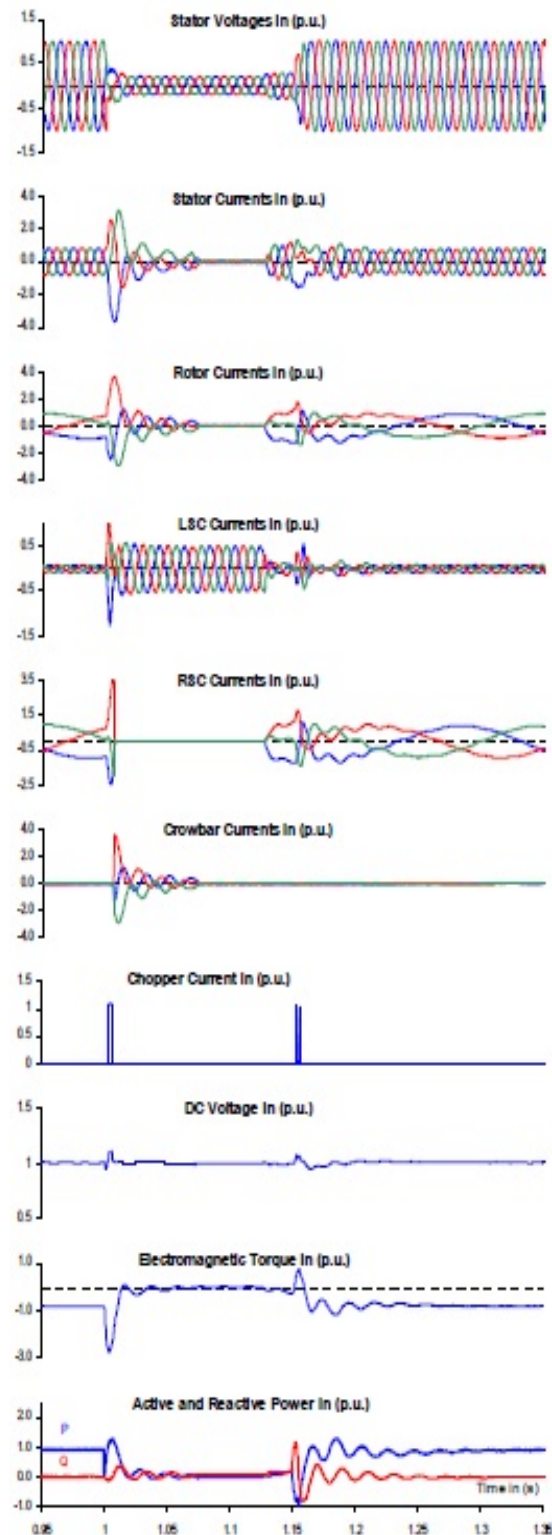

Fig.7. FRT example with only one crowbar period by using both crowbar and DC-link chopper as well

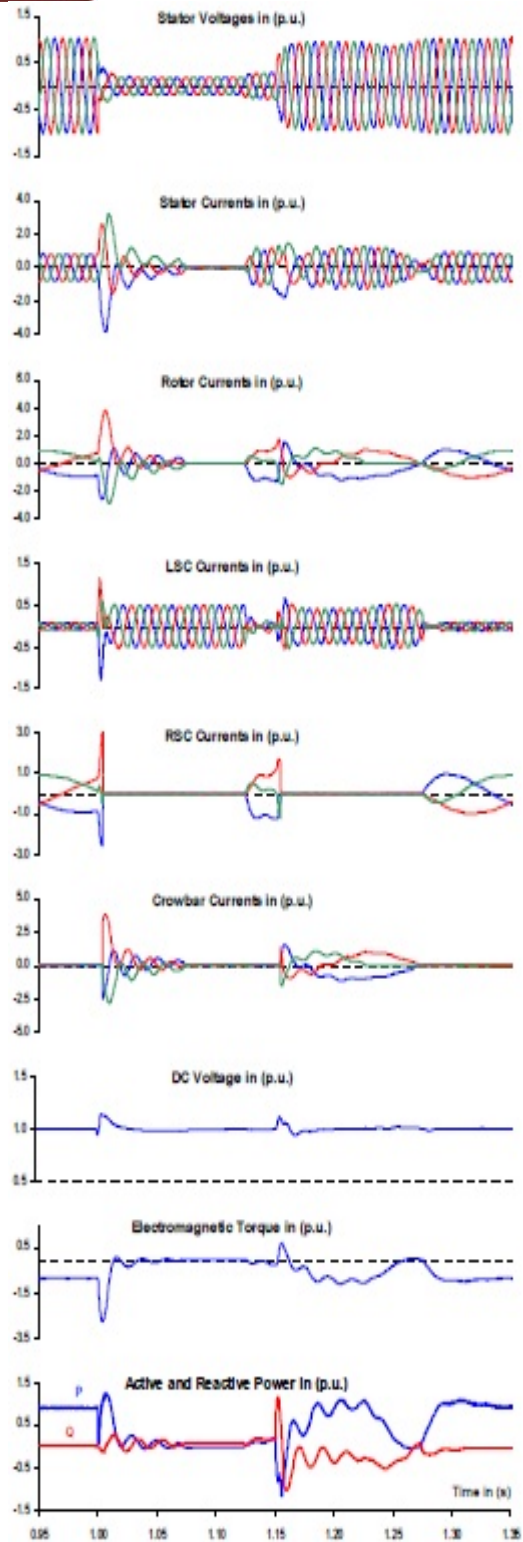

Fig.8. FRT example with a second crowbar period after voltage recovery (no chopper is implemented)

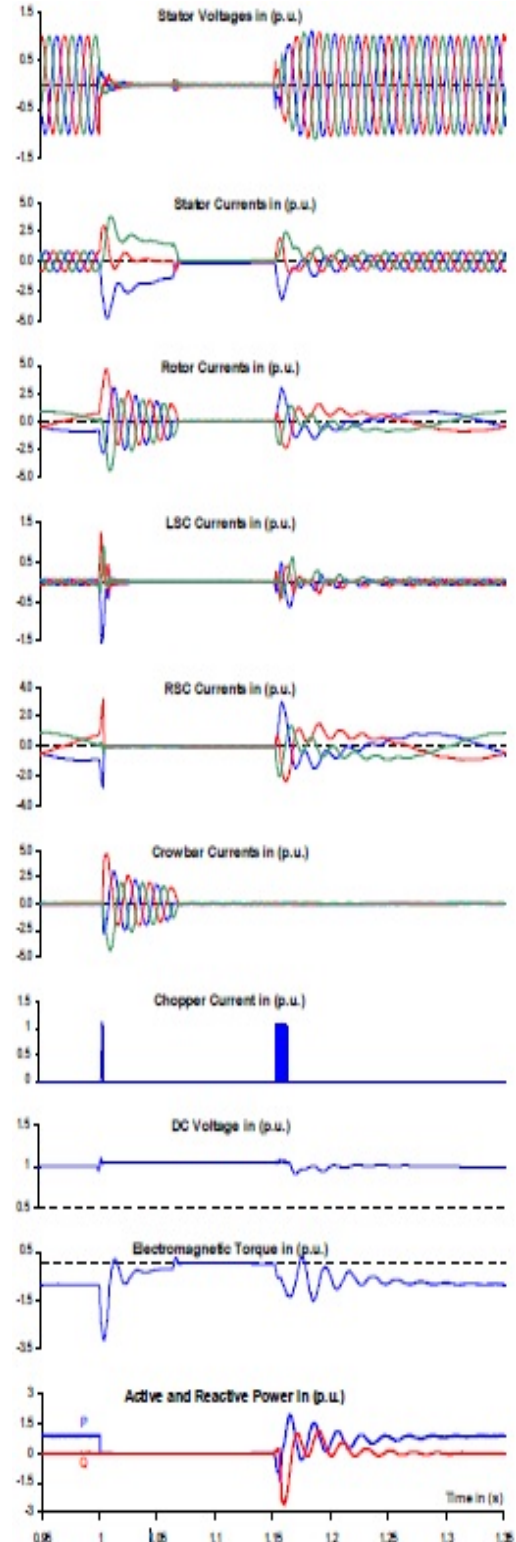

Fig.9. Zero voltage ride through by using both crowbar and DC-link chopper as well

## V. CONCLUSIONS

The classical control techniques for regulating the active and reactive power delivery in doubly fed induction generators (DFIG), for wind power applications, are normally based on voltage oriented control (VOC) strategies. DFIG based wind turbine systems are heavily

stressed during grid faults. To guarantee grid connectivity even at zero grid voltage in accordance with utility requirements special FRT measures are necessary. Wind turbines equipped with rotor crowbar and DC-link chopper are able to stay on grid and limit currents and voltages below the threshold values. Since during the crowbar period the DFIG is not controllable, reactive current support to the grid is provided by the LSC, which may result in a temporary overload. However, the LSC has also to control the active power flow through the converter by controlling the DC-link voltage that always has to be ensured by the LSC control. A second crowbar period after voltage recovery represents the worst case scenario for the grid because of the high reactive power demand. However, with a well-designed DC-chopper the crowbar firing at the moment of voltage recovery can be precluded, which caters not only for the needs of the transmission network, but also for secure, safe operation of the mechanical shaft system of the wind turbine.

## REFERENCES

- [1] I. Erlich, U. Bachmann, "Grid code requirements concerning connection and operation of wind turbines in Germany", Power Engineering Society General Meeting, 2005. IEEE, June 12-16, 2005 Page(s): 2230 – 2234.
- [2] I. Erlich, W. Winter, A. Dittrich „Advanced Grid Requirements for the Integration of Wind Turbines into the German Transmission System” IEEE-PES General Meeting Montreal 2006, panel paper 06GM0837
- [3] T. Burton, D. Sharpe, N. Jenkins, E. Bossanvi, Wind Energy Handbook, John Wiley & Sons, Ltd, 2001.
- [4] Müller, S.; Deicke, M.; De Doncker, R. W.:Adjustable speed generators for wind turbines based on doubly-fed induction machines and 4-quadrant IGBT converters linked to the rotor. Records of the IEEE IAS Conference, Rome, CD, 2000.
- [5] Datta R., Ranganathan V. T.: Decoupled control of active and reactive power for a grid-connected doublyfed wound rotor induction machine without position sensors, In Conference Record of the 1999 IEEE Industry Applications Conference. Thirty-Fourth IAS Annual Meeting (Cat. No.99CH36370), pp. 2623-2628.
- [6] Geniusz A., Krzeminski Z.: Control system based on the modified multiscalar model for the Double Fed Machine, Records of the PCIM Conference, Nürnberg, 2005
- [7] Krzeminski Z.: Sensorless Multiscalar Control of Double Fed Machine for Wind Power Generators, Osaka 2002
- [8] Leonhard W.: Control of Electrical Drives. Springer-Verlag, 2nd Edition, 1996.
- [9] Peresada, S., Tilli A., Tonielli A.: Power control of a doubly fed induction machine via output feedback, Control Engineering Practice, 12, pp. 41-57, 2004.
- [10] Petersson A.: Analysis, Modeling and Control of Doubly- Fed Induction Generators for Wind Turbines, Thesis for the degree of licentiate of engineering, Department of Electric Power Engineering, Chalmers University of Technology Goteborg, Sweden 2003
- [11] A. Geniusz, S. Engelhardt: . Riding through Grid Faults with Modified Multiscalar Control of Doubly Fed Asynchronous Generators for Wind Power Systems Records of the PCIM Conference, Nürnberg, 2006.

## AUTHOR'S PROFILE



### **Bibhu Prasad Nanda**

received his B. Tech. Degree from BPUT University at Odisha, India. After that he received his M. Tech degree from KIIT University, Odisha, India.

He is working as Asst. Professor at SYNERGY Institute of Technology, Bhubaneswar, Odisha, India. His research interest includes renewable energy sources, Power electronics application towards smart grid, Artificial Intelligence applications towards Drives and their control schemes. Email: bibhunanda1986@yahoo.com