

Antenna Bandwidth Enhancement Using Metamaterial Structure

Parminder Singh
parminder.db@gmail.com

Kanchan Jaswal
kanchanjaswal98@gmail.com

Jyotsana Chandel
chandel.jyotsana2@gmail.com

Monika Suman
suman.monika9@gmail.com

Abstract — Microstrip patch antenna becomes very popular day by day because of its ease of analysis and fabrication, low cost, light weight, easy to feed and their attractive radiation characteristics. Although patch antenna has numerous advantages, it has also some drawbacks such as restricted bandwidth, low gain. In this paper, an attempt has been made to increase the bandwidth of Microstrip patch antenna using metamaterial structure. Metamaterials, also called left-handed materials (LHMs), are a class of composite materials artificially built to exhibit unusual properties not found in nature. Metamaterial exhibiting negative permittivity and negative permeability in certain frequency range or known as left-handed material (LHM). CST MWS and MATLAB Softwares are used for the simulation and design calculations of the microstrip antennas. The return loss, bandwidth, gain, radiation pattern are evaluated. Using CST MWS simulation software proposed antenna is designed/simulated and optimized. The antenna exhibits a bandwidth of 0.12792GHz and the same antenna exhibits a bandwidth of 0.13166GHz when made by using a metamaterial SRR structure at frequency of 3.4 GHz. The variation in the bandwidth is due to the metamaterial structure used.

Keywords — Microstrip Antenna, CST Microwave Studio, MATLAB, SRR Structure.

I. INTRODUCTION

The microstrip antenna have a number of useful properties such as small size, low-cost fabrication, low profile, light weight, conformability, ease of installation and integration with feed networks but one of the serious limitations of these antennas have been their narrow bandwidth characteristics as it limits the frequency ranges over which the antenna can perform satisfactorily. These features are major design considerations for practical applications of microstrip antennas. Recent technologies enable wireless communication devices to become physically smaller in size. Antenna size is obviously a major factor that limits miniaturization. Modern wireless communication system requires low profile, light weight, high gain, and simple structure antennas to assure reliability, mobility, and high efficiency characteristics. Microstrip antenna satisfies such requirements. The key features of a microstrip antenna are relative ease of construction, light weight, low cost and either conformability to the mounting surface or, an extremely thin protrusion from the surface. This antenna provides all of the advantages of printed circuit technology. These advantages of microstrip antennas make them popular in many wireless communication applications such as satellite communication, radar, medical applications, etc. The limitations of microstrip antennas are narrow

frequency band and disability to operate at high power levels of waveguide, coaxial line or even stripline. Therefore, the challenge in microstrip antenna design is to increase the bandwidth and gain. The choosing of design parameters (dielectric material, height and frequency, etc) is important because antenna performance depends on these parameters. Radiation performance can be improved by using proper design structures. The use of high permittivity substrates can miniaturize microstrip antenna size. Thick substrates with lower range of dielectric offer better efficiency, and wide bandwidth but it requires larger element size. Different radar systems such as synthetic aperture radar (SAR), shuttle imaging radar, remote sensing radars, and other wireless communication systems operate in L, C and X bands. Microstrip antenna is the first option for this high frequency band such as X-band due to its low cost, light weight, and robustness. This article provides a way to choose the design parameters of antennas to achieve the desired dimensions as well as the characteristics for the effective radiation efficiency. It is important to have the proper antenna for a device. The proper miniaturized antenna will improve transmission and reception, reduce power consumption, last longer and improve marketability of the communication device. In this paper, antenna with bandwidth 0.12792 GHz and same antenna designed using metamaterial structure with bandwidth 0.13166 GHz is designed and simulated using CST Microwave Studio. The proposed patch antenna resonates at 3.4 GHz frequency.

II. GEOMETRY OF MICROSTRIP PATCH ANTENNA AND METAMATERIAL SLAB

In this antenna, the substrate has a thickness $h=1.2$ mm and a relative permittivity $\epsilon_r = 4.3$. The length and width of patch are $L=20.994$ mm and $W=27.1013$ mm respectively. The length and width of ground are $L=28.194$ mm and $W=34.3012$ mm respectively. Edges along the width are called radiating edges and that along the length are called non radiating edges. It can be fed by different methods like microstrip line feed, coaxial probe feed, aperture coupling, electromagnetic coupling and coplanar waveguide (CPW). In this work, microstrip line (50 ohm) feed has been used. Antenna is designed for a resonating frequency of 3.4 GHz and by making use of optimization techniques it is analyzed using CST Microwave Studio software. For the designing of rectangular microstrip antenna, the following relationships are used to calculate the dimensions of rectangular microstrip patch antenna.

$$\epsilon_{\text{reff}} = \frac{\epsilon_r + 1}{2} + \frac{\epsilon_r - 1}{2} \left[1 + 12 \frac{h}{W} \right]^{-\frac{1}{2}}$$

$$L_{\text{eff}} = \frac{c}{2f_o \sqrt{\epsilon_{\text{reff}}}}$$

$$\frac{\Delta L}{h} = 0.412 \frac{(\epsilon_{\text{reff}} + 0.3) \left(\frac{W}{h} + 0.264 \right)}{(\epsilon_{\text{reff}} + 0.258) \left(\frac{W}{h} + 0.8 \right)}$$

$$L = L_{\text{eff}} - 2\Delta L$$

$$f_r = \frac{1}{2L \sqrt{\epsilon_r \epsilon_o \mu_o}} = \frac{V_o}{2L \sqrt{\epsilon_r}}$$

$$W = \frac{1}{2f_r \sqrt{\mu_o \epsilon_o}} \sqrt{\frac{2}{\epsilon_r + 1}}$$

$$W_g = 6h + W$$

$$L_g = 6h + L$$

Where,

h = substrate thickness

L = length of patch

L_{eff} = effective length

W = width of patch

c = speed of light

f_r = resonant frequency

ϵ_r = relative permittivity

ϵ_{reff} = effective permittivity

L_g = Length of ground plane

W_g = Width of ground plane

The various formulae used for the calculation of srr structure:

For effective magnetic permeability

$$\mu_{\text{eff}} = \frac{1 - Ff^2}{(f^2 - f_m^2 + i\gamma_m f)}$$

Where,

f_m = resonance frequency which depends the SRR structure.

F = filling factor of SRR in one unit cell

γ_m = damping factor

$$2\pi\gamma_m = \frac{2L_x \rho}{r}$$

Where,

ρ = resistivity of metal

C = velocity of light

For Effective permittivity

$$\epsilon_{\text{eff}} = \frac{1 - f_e^2}{(f^2 + i\gamma_e f)}$$

f_e is the electronic frequency with

$$f_e^2 = \frac{c^2}{[2\pi a^2 \ln(\frac{a}{r})]}$$

III. DESIGN PARAMETERS

Figure 1 and Figure 2 shows the front view geometry and the structure designed on CST Microwave Studio software of proposed microstrip line fed patch antenna with single band operation and metamaterial based designed structure. The dimensions and feed point location for proposed antenna have been optimized so as to get the best possible impedance match to the antenna. The following parameters are used for design of proposed antenna.

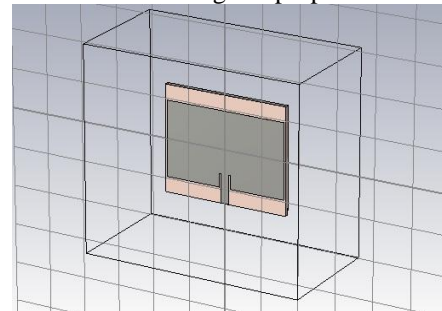

Fig.1. Designed Structure on CST Microwave studio.

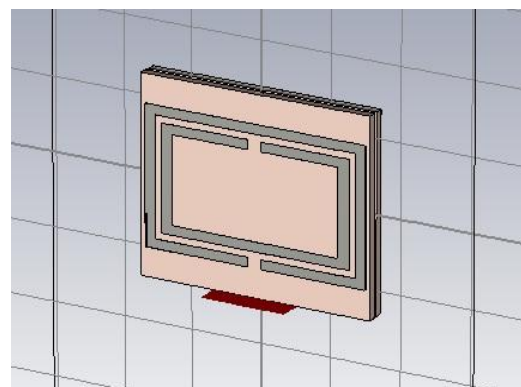

Fig.2. Designed Metamaterial Structure on CST Microwave studio.

Design frequency = 3.4 GHz

Substrate permittivity = 4.3

Thickness of substrate = 1.2 mm

Length of patch (L) = 20.994 mm

Width of patch (W) = 27.1013 mm

Length of Ground (L_g) = 28.194mm

Width of Ground (W_g) = 34.3012 mm

IV. SIMULATED RESULTS

The parameters for the designed antenna were calculated and the simulated return loss result for both the designed structures are shown in Figure 3(a) and Figure 3(b). The bandwidth at the 3.4 GHz band is around 127.92 MHz with the corresponding value of return loss as -36.06 dB and bandwidth of antenna designed using metamaterial structure 131.66 MHz with the corresponding value of return loss as -23.599 dB. The bandwidths so achieved are shown in Figure 4(a) and figure 4(b). The achieved antenna impedance is 50.4 ohm and 46.04 ohm as shown in Figure 4(c) and Figure 4(d) respectively, which is very close to the required impedance of 50 ohm. The VSWR ratio is 1:1.2 is shown in Figure 5(a) and 5(b), which should lie in between 1 and 2. Figure 6(a) and 6(b) shows the simulated 3-D radiation pattern at frequency of 3.4GHz. It shows that proposed antenna radiates in omni-directional nature.

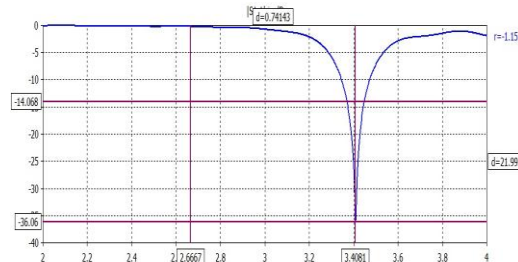

Fig.3(a). Simulated Return loss curve for antenna structure

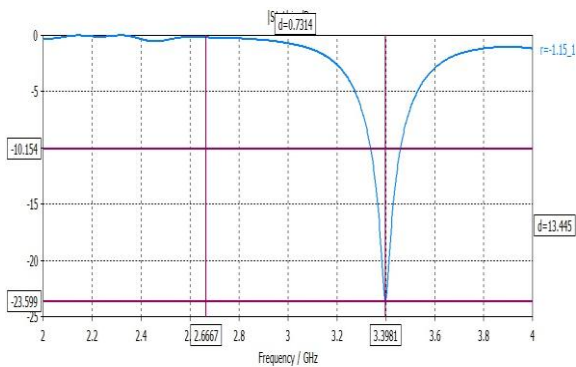

Fig.3(b). Simulated Return loss curve for metamaterial structure

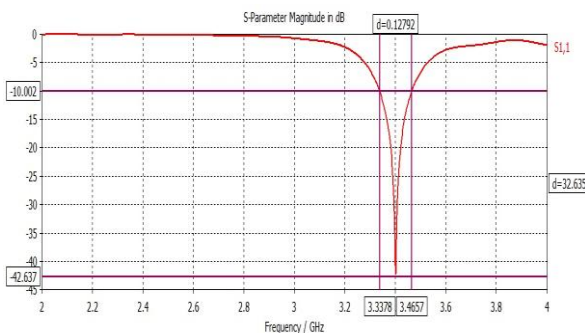

Fig.4(a). Bandwidth plot for antenna structure

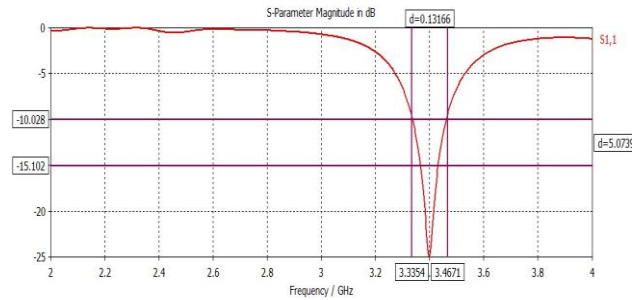

Fig.4(b). Bandwidth plot for metamaterial structure

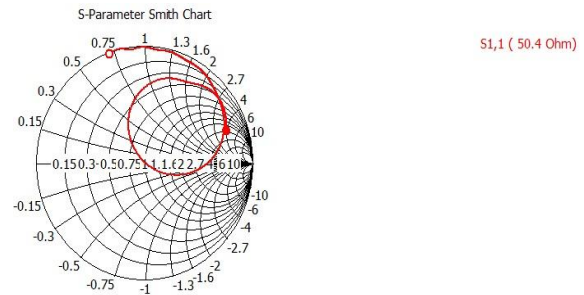

Fig.4(c). Curves showing Antenna characteristic Impedance

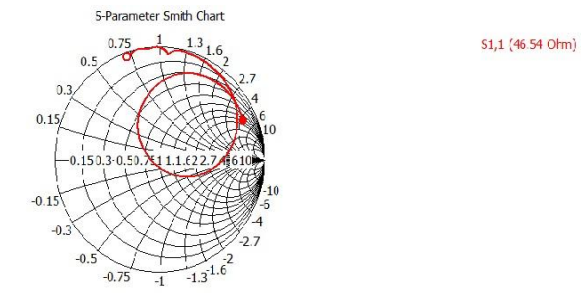

Fig.4(d). Curves showing Metamaterial structure impedance

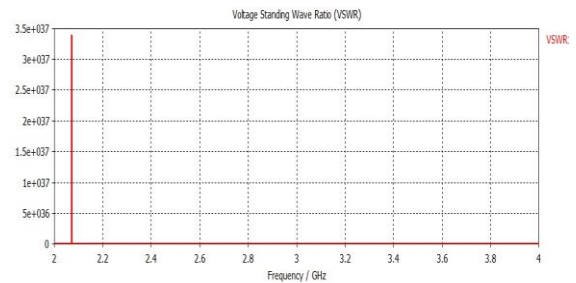

Figure 5(a): VSWR Curve for antenna structure

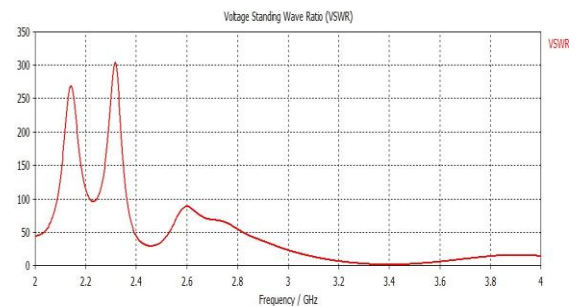

Fig.5(b). VSWR Curve for metamaterial structure

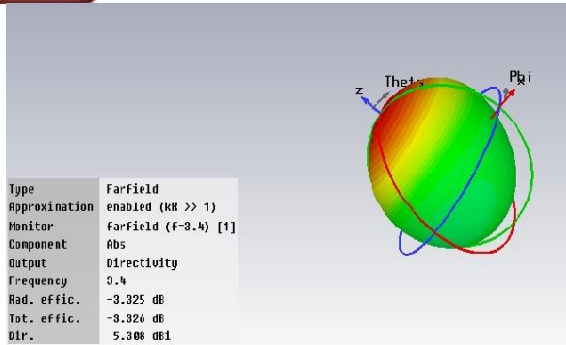

Fig.6(a). 3-D Radiation Pattern of Antenna structure at 3.4 GHz

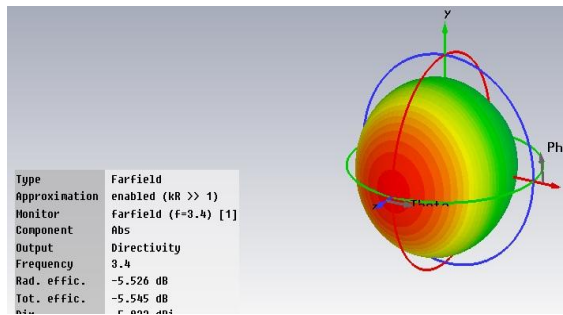

Fig.6(b). 3-D Radiation Pattern of Metamaterial structure at 3.4GHz.

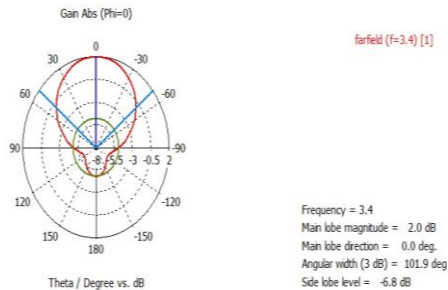

Fig.7(a). Elevation Radiation Pattern of proposed microstrip patch antenna at 3.4 GHz.

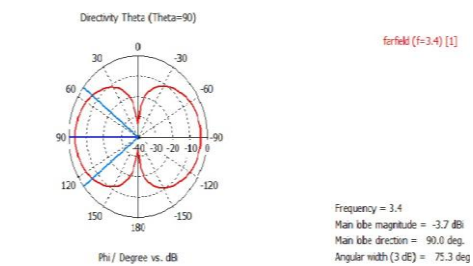

Fig.7(b). Azimuthal Radiation Pattern of proposed patch Antenna at 3.4 GHz

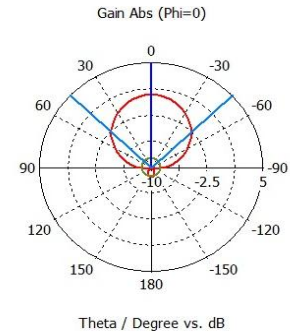

Fig.7(c). Elevation Radiation Pattern of proposed metamaterial structure at 3.4 GHz.

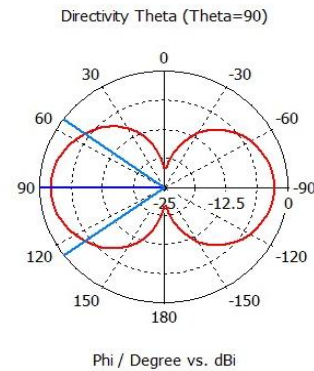

Fig.7(d). Azimuthal Radiation Pattern of proposed metamaterial at 3.4 GHz.

V. CONCLUSION

A microstrip line fed single frequency microstrip patch antenna has been designed and simulated using CST Microwave Studio software. This is operating at the frequency of 3.4 GHz. The simulated impedance bandwidth at the 3.4 GHz band is around 127.92 MHz with the corresponding value of return loss as -36.06 dB of antenna design and 131.66MHz of bandwidth with -23.599dB of return loss of metamaterial designed structure and which is small enough and frequency is closed enough to the specified frequency band feasible for WLAN application. An omni-directional radiation pattern result has been obtained which seems to be adequate for the envisaged applications. Thus it shows that the bandwidth of metamaterial designed structure is more as comparison to ordinary antenna design. Work is going on to achieve even better results with good axial ratio over a wide bandwidth.

REFERENCES

- [1] Mst. Nargis Aktar, Muhammad Shahin Uddin, Md. Ruhul and Md. Mortuza Ali "Enhanced Gain and Bandwidth of Patch Antenna using EBG Substrates" IJWMN Vol.3, No. 1, February 2011.
- [2] Constantine A. Balanis "Antenna Theory Analysis and Design", Third edition: A JOHN WILEY & SONS, inc publication.
- [3] STC on "Antenna Design" held at Thappar University, Patiala.

- [4] M A Matin, M.P Saha, H. M. Hasan “Design of Broadband Patch Antenna for WLAN” ICMMT 2010 Proceedings.
- [5] Kin-Lu Wong, “Compact and Broadband Microstrip Antennas”, Copyright 2002 John Wiley & Sons, Inc.
- [6] D. M. Pozar and D. H. Schaubert, Microstrip Antennas, “The Analysis and Design of Microstrip Antennas and Arrays”, IEEE Press, 1995.
- [7] K.D.Prasad “Antenna and Wave Propagation Satya Prakashan, New Delhi”.
- [8] Hu, J., Yan, C.-S. and Lin, Q.-C. (2006). A New Patch Antenna With Metamaterial Cover: Zhejiang University SCIENCE A.
- [9] Aydin, K., Guven, K. and Ozbay, E. (2006). Two-Dimensional Left-Handed Metamaterial with a Negative Refractive Index. Journal of Physics: Conference Series 36(2006)
- [10] Mohammad Tariqul Islam, Mohammed Nazmus Shakib, Norbahiah Misran, and Baharudin Yatim, “Analysis of Broadband Slotted Microstrip Patch Antenna,” Proceedings of the International Conference on Computer and Information Technology, December 2008, pp. 758-761.
- [11] D. M. Pozar, “Microwave Engineering,” Third edition. New York, Wiley, 2005.
- [12] Constantine A. Balanis, “ Antenna Theory Analysis and Design,” Third Edition, John Wiley & Sons, 2005
- [13] T. A. Milligan, et al. (2005). Modern antenna design. Available: <http://dx.doi.org/10.1002/0471720615>.
- [14] M. I. Skolnik, Introduction to radar systems, 3rd ed. New York: McGraw-Hill, 2000.
- [15] Caratelli, D., R. Cicchetti, G. Bit Babik, and A. Faraone, A perturbed E-shaped patch antenna for wideband WLAN applications,” .
- [16] Jakšić, Zoran, Dalarsson, Nils, & Maksimović, Milan, “Negative Refractive Index Metamaterials: Principles and Applications,” June 2006.
- [17] Chen, Xudong, Grzegorzcyk, Tomasz M., Wu, Bae-Ian, Pacheco Jr., Joe, & Kong, Jin Au, “Robust Method to Retrieve the Constitutive Effective Parameters of Metamaterials,” *Phys. Rev. E.*, **70**, 016608, (2004).
- [18] Eleftheriades, G. V., “Negative-Refractive-Index Transmission-Line Metamaterials and Enabling Microwave Devices,” *The Radio Science Bulletin*, No. 312 (2005).



Jyotsana Chandel

Is pursuing her B.Tech. (ECE) degree from Doaba Women Institute of Engineering and Technology. Her area of interest is antenna design and simulation.
Email: chandel.jyotsana2@gmail.com



Monika Suman

Is pursuing her B.Tech. (ECE) degree from Doaba Women Institute of Engineering and Technology. Her area of interest is antenna design and simulation.
Email: suman.monika9@gmail.com

AUTHOR’S PROFILE



Parminder Singh

Has received his B.Tech. (ECE) degree from Institute of Engineering & Technology, BHADDAL, Punjab Technical University, Jalandhar in 2008. Currently he is working as HOD (ECE) in Doaba Women Institute of Engineering & Technology, Kharar. He has three year ten months of teaching experience. He is pursuing his PG programme in Department of

Electronics and Communication Engineering at Institute of Engineering & Technology, BHADDAL, Punjab Technical University, Jalandhar. His area of interest is Antenna Design, study of behaviour of electromagnetic waves.

Email: parminder.db@gmail.com



Kanchan Jaswal

Is pursuing her B.Tech (ECE) degree from Doaba Women Institute Of Engineering and Technology. Her area of interest is antenna design and simulation.
Email : kanchanjaswal98@gmail.com