

# Medical and Natural Image Denoising by Split Bregman's Total Variation Filtering with Wavelet Thresholding

Vikas Gupta, Kriti Shukla

**Abstract** – In this paper a new method of image denoising is proposed. This method combines two very popular techniques of denoising, Wavelet decomposition and total variation filtering. We will use this method for denoising of medical images as well as natural images. In this algorithm, a noisy image is first decomposed in its wavelet coefficients. Then these coefficients filtered by soft thresholding. This threshold is calculated by total variation method. Inverse wavelet transform of filtered and modified coefficients of image give the reconstruction of denoised image. Total variation minimization filter will sufficiently remove noisy coefficients and retain fine edge information of image. Very few iteration of TV will produce denoised image with edge information. Split bregman method is applied for TV minimization. In terms of PSNR values, this combination will produces better results.

**Keywords** – AWG noise, image denoising, split bregman method, total variation (TV), wavelet thresholding.

## I. INTRODUCTION

The goal of denoising is to remove the noise while preserving the important image information as much as possible. Traditional filters introduce blurring effect to the image and wavelet is failed in keeping edge information [1], [6].

Noise may be generated due to imperfect instruments used in image processing, problems with the data acquisition process, and interference, all of which can degrade the data of interest. Most of the natural images are assumed to have additive random noise, which is modeled as Gaussian type (AWGN). Speckle noise is observed in ultrasound images, whereas rician noise affects MR images. Noise in a digital image has low as well as high frequency components [9], [10].

The algorithm presented in this paper is based on wavelet threshold filtering and total variation minimization method, which exploits the potential features of both wavelet thresholding and total variation filter at the same time their limitations are overcome. Algorithm works as a wavelet domain low pass filter for high frequency noisy detail components of image and TV minimizer for low frequency noisy edge coefficients. The proposed method gives better denoising over other spatial and wavelet domain filters keeping edge information and other detail of image very well and PSNR of the image after denoising is optimal.

In this algorithm, first image is decomposed in wavelet sub-bands, LL, LH, HL and HH. The LL sub-band of noisy image is used to find the horizontal, vertical and diagonal edges [3]-[4]. Using the pixel position of horizontal edges, the corresponding wavelet coefficients in

HL sub-band are retained and using a proper threshold value, thresholding others to zero. Adopting the same procedure the vertical and diagonal details of LH and HH sub-bands is retained. By applying inverse wavelet transform on modified wavelet coefficients, we get back the image with a partial noise. This partial noise can be removed using TV filter with single iteration.

In this research paper, section 2 introduces wavelet decomposition and thresholding, whereas section 3 presents concept of total variance. Section 4 gives introduction of split bregman's solution of TV minimization problem. New proposed algorithm is discussed in section 5. Implementation reference is given in section 6. Expected Performance of proposed algorithm is presented in section 7. PSNR result is discussed in section 8. Finally the conclusions have been drawn in section 9.

## II. WAVELET DECOMPOSITION AND THRESHOLDING

After wavelet transformation, most of the energy of signal is supposed to be clustered in a few wavelet coefficients [7], whereas noises are not. The thresholding, or shrinkage on the wavelet coefficients with a proper threshold [12], can then significantly reduce the noise. The key point of wavelet threshold denoising is selecting a proper threshold, the higher the threshold is, the better effect of denoising will be, and, at the same time, the blurrier the edge will be.

### A. Wavelet Thresholding Based Denoising Algorithm

In wavelet domain methods, the noisy image is decomposed to around five level of decomposition for efficient denoising. This leads to increase in computational complexity. Any kind of decomposition of an image into wavelets involves a pair of waveforms: one to represent the high frequencies corresponding to the detailed parts of an image (wavelet function) and another for the low frequencies or smooth parts of an image (scaling function) [2]-[4]. Fig. 1 shows its operation.

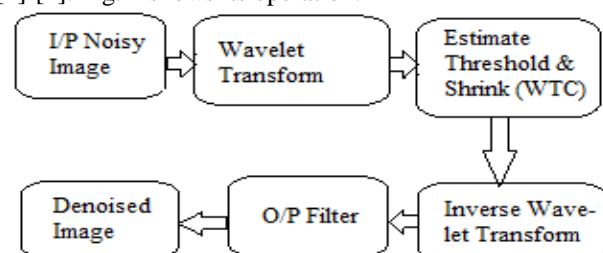

Fig.1. wavelet thresholding for image denoising

Let  $W$  and  $W^{-1}$  denote the two dimensional orthogonal discrete wavelet transform (DWT) matrix and its inverse, respectively. Then  $Y = W.g$  represents the matrix of wavelet coefficients of  $g$  having four sub-bands (LL, LH, HL and HH) [7]. The sub-bands  $HH_k$ ,  $HL_k$ , and  $LH_k$  are called details, where  $k$  is the scale varying from 1, 2 and  $J$ , where  $J$  is the total number of decompositions. The LL has the average information, LH has the details across the horizontal direction, and the HL has the details across the vertical direction whereas HH has the details across the diagonal direction. The wavelet thresholding denoising method processes each coefficient of  $Y$  from the detail sub-bands with a soft threshold function to obtain  $X$ . The denoised estimate is inverse transformed to  $f = W^{-1}X$ .

Soft thresholding function with threshold  $T$  [2], [3].

$$X[n] = \begin{cases} Y[n] - T & Y[n] \geq T \\ Y[n] + T & Y[n] \leq -T \\ 0 & |Y[n]| < T \end{cases}$$

Where  $T$  is the threshold value calculated by total variational method, discussed in next section. Disadvantage of this method is that it produces blurring effect at the edge of image. In case of medical images blurred edge may results in wrong diagnosis.

### III. TOTAL VARIATION METHOD

Total variation based filtering was introduced by Rudin, Osher, and Fatemi [5]. TV denoising is an effective filtering method for recovering piecewise-constant signal. 'TV/ROF Denoising' in the form of BV or Besov norm

$$\min_u \|u\|_{BV} + \frac{\mu}{2} \|u - f\|_2^2 \quad (3.1)$$

In that paper, the authors propose to minimize this energy using a gradient projection method. While this approach is simple, the non-linearity and poor conditioning of the problem make this approach very slow.

Let the noisy image is  $u_0(x,y) = u(x,y) + N(x,y)$  where  $u(x,y)$  denotes the desired clean image and  $x,y \in \Omega$ .  $N$  is the additive noise. The total variation denoising modal can be stated as follows:

$$u_t = \frac{\partial}{\partial x} \left( \frac{u_x}{\sqrt{u_x^2 + u_y^2}} \right) + \frac{\partial}{\partial y} \left( \frac{u_y}{\sqrt{u_x^2 + u_y^2}} \right)$$

-  $(u-u_0)$ , for  $t > 0$ ,  $x, y \in \Omega$

' $\lambda$ ' is the tuning or regularization or minimization parameter [8], [11]. This is used to balance the tradeoff between the suppression of oscillations and fitting term. Larger value of  $\lambda$  gives blurring effect to the image. A careful selection of this parameter gives better denoised image with fine edge information and other details [5]. can be calculated as

$$\lambda = \frac{\iint_{\Omega} \text{div} \left( \frac{\nabla u}{|\nabla u|} \right) (u - u_0) dx dy}{2\sigma^2 |\Omega|}$$

Total variation method provides smoothness to the homogeneous region while retaining the edges.

### IV. SPLIT BREGMAN ANISOTROPIC TV DENOISING METHOD

The general form of l1 regularized problems is

$$\min_u |\Phi(u)| + H(u) \quad (4.1)$$

Where  $|\cdot|$  denotes the l1-norm, and both  $|\cdot|$  ( $u$ ) and  $H(u)$  are convex functions. Many important problems in imaging science (and other computational areas) can be posed as l1-regularized optimization problems. One of them is shown in ROF method eq. (3.1) [13].

The anisotropic problem is

$$\min_u |\nabla_x u| + |\nabla_y u| + \frac{\mu}{2} \|u - f\|_2^2 \quad (4.2)$$

Applying Bregman iteration and iterative minimization approach to solve this problem [13]-[15]. The optimality condition which gives optimal efficiency with iterative algorithm is given below:

$$(\mu I - \lambda \Delta) u^{k+1} = \mu f + \lambda \nabla_x^T (d_x^k - b_x^k) + \lambda \nabla_y^T (d_y^k - b_y^k)$$

The Gauss-Seidel solution of this problem can be written component wise as:  $u_{i,j}^k = G_{i,j}^k$ . Where

$$G_{i,j}^k = \frac{\lambda}{\mu + 4\lambda} (u_{i+1,j}^k + u_{i-1,j}^k + u_{i,j+1}^k + u_{i,j-1}^k + d_{x,i-1,j}^k - d_{x,i,j}^k + d_{y,i,j-1}^k - d_{y,i,j}^k - b_{x,i-1,j}^k + b_{x,i,j}^k - b_{y,i,j-1}^k + b_{y,i,j}^k) + \frac{\mu}{\mu + 4\lambda} f_{i,j}$$

Split Bregman method decouples the l1 and l2 portions of the energy. Split Bregman algorithm for anisotropic TV denoising is written as:

Initialize:  $u^0 = f$ , and  $d_x^0 = d_y^0 = b_x^0 = b_y^0 = 0$

While  $\|u^k - u^{k-1}\|_2 > \text{tol}$

$u^{k+1} = G_{i,j}^k$

$d_x^{k+1} = \text{shrink}(\nabla_x u^{k+1} + b_x^k, 1/)$

$d_y^{k+1} = \text{shrink}(\nabla_y u^{k+1} + b_y^k, 1/)$

$b_x^{k+1} = b_x^k + (\nabla_x u^{k+1} - d_x^{k+1})$

$b_y^{k+1} = b_y^k + (\nabla_y u^{k+1} - d_y^{k+1})$

end

Where  $u^{k+1} = G_{i,j}^k$  is Gauss Seidel solution.

### V. PROPOSED DENOISING METHOD

Block diagram shown in fig. 2 is the representation of new proposed denoising algorithm.

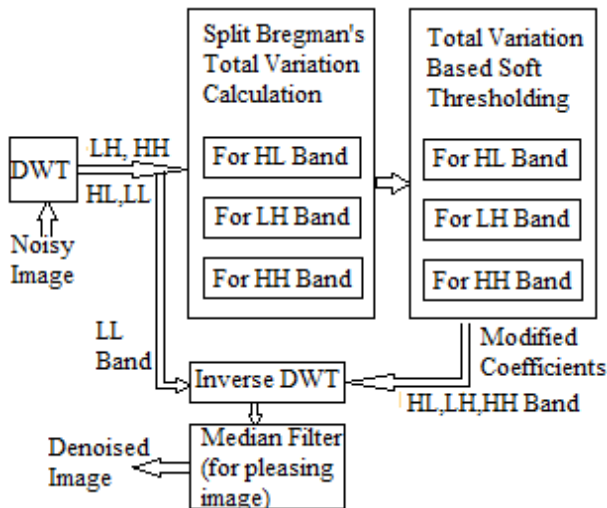

Fig.2. Block diagram of proposed algorithm

This is an improved algorithm which utilizes only useful feature of wavelet and TV filtering. Soft thresholding of wavelet coefficients is performed using the local threshold value which is calculated using Split bregman's method of TV minimization.

#### A. Description of Block's Function

First block is input block which provides noisy image for next decomposition block. Second block will take the wavelet transform of input noisy image and decompose it in to 4 sub bands (LL, LH, HL and HH). For less noisy LL sub bands TV minimization with soft thresholding is performed. Horizontal, vertical and diagonal noisy wavelet coefficients from LL band image are diagnosed. This edge information is used in thresholding of other bands i.e. LH, HL, HH band. Now all four bands with modified coefficients are then forwarded to inverse wavelet transform block for the retrieval of denoised image. For more pleasing image with fine edge information and detailed information one median filter can be introduced in the next block, which will finally produce noiseless smooth image with sharp edges.

#### B. Steps of Algorithm

As stated above the proposed method follows these steps:

##### ➤ Step 1

The noisy image is decomposed in wavelet domain. Out of four sub-bands (LL, HL, LH, and HH), the LL sub-band contains low frequency components with small amount of noise. Fig. 3 shows this decomposition.

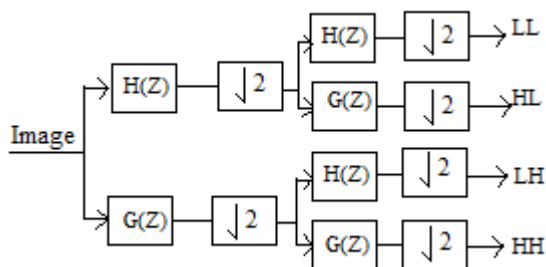

Fig.3. Wavelet decomposition

##### ➤ Step 2

LL sub band already has less noisy image. A little noise is present at the edges. Small amount of noise is removed by proposed method. Pixel position of noisy horizontal, vertical, and diagonal edge coefficients is noted from LL band. .

##### ➤ Step 3

Taking the pixel positions of these edges the corresponding wavelet coefficients of HL, LH and HH sub-bands are retained thresholding others to zero according to proposed method.

##### ➤ Step 4

Finally denoised image is reconstructed by inverse discrete wavelet transform (IDWT) of these modified wavelet coefficients.

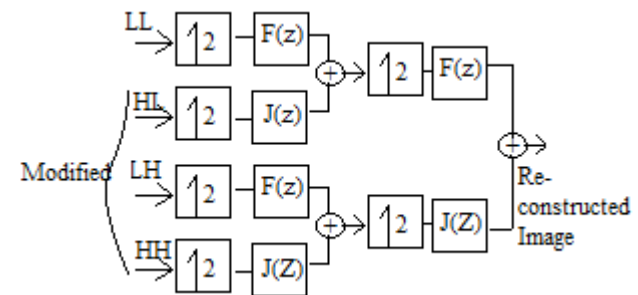

Fig.4. Reconstruction of modified (HL, LH, HH) and LL coefficients.

##### ➤ Step 5

For more pleasing image quality we can add median filter before our final denoised image.

#### C. PSNR Analysis

Peak signal to noise ratio is the parameter which is calculated for the result analysis.

$$\text{PSNR (db)} = 20 \times \log_{10}(255 / \epsilon)$$

Where  $\epsilon$  is RMSE (root mean square error) given by:

$$\epsilon = \sqrt{\frac{1}{N} \sum_x \sum_y (f(x, y) - \hat{f}(x, y))^2}$$

Where, N is the total number of pixels and  $f, \hat{f}$  are original and filtered image respectively.

## VI. IMPLEMENTATION REFERENCE

Proposed method is easy to implement with MATLAB or C++ Platform. Proposed implementation of this denoising method can be easily done in MATLAB 7.5 platform. Preferred image size for this test is 512x512. Bior 6.8 filter will be preferred. Noise introduced is zero mean white Gaussian noise with 0.05 variance (in Matlab).

## VII. EXPECTED RESULTS

Various medical images like ultrasound (USG), MR images (MRI), and CT images and X-ray images can be denoised by this proposed combination of two methods. This method can also be used for natural image denoising. Fig. 5 shows test result of proposed method on various images.

Column 5(a) shows the original image. This image is mixed with a known noise in 5(b), expected result after passing through our proposed denoising filter is presented in 5(c). From figure 5, it is clear that the denoised image is most similar to the original image, having most of the edge information with denoised detailed information.

### VIII. PSNR RESULTS

Results of this new method are analyzed on the PSNR terms. Table I shows the result of denoising using proposed algorithm on various types of image.

Table I:

Image	Lena	MRI	CT	Ultra-sound	X-Ray
PSNR (in dB)	37.46	28.13	28.03	30.45	27.77

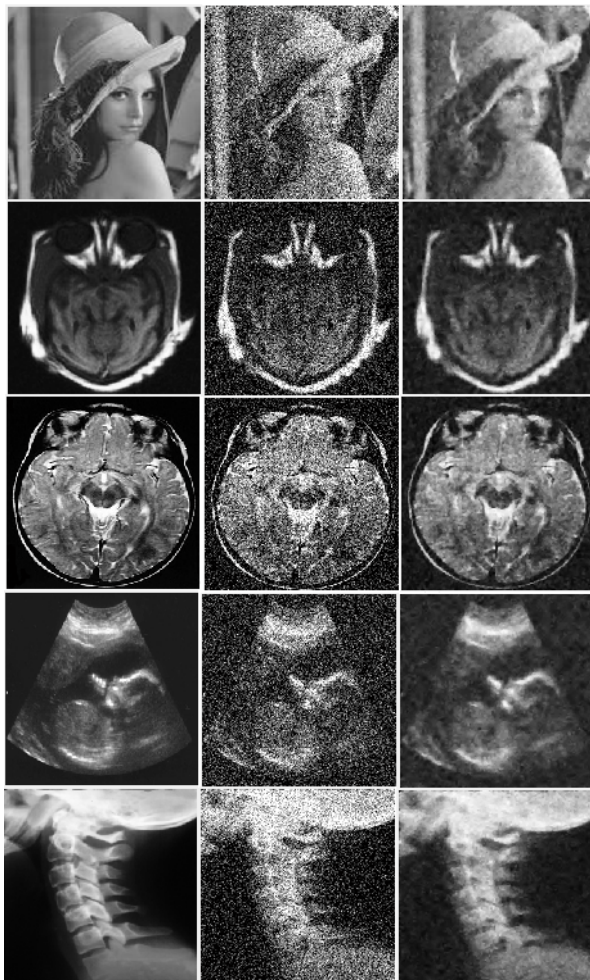

(a) Original image (b) Noisy image (c) denoised image  
 Fig.5. Initial results of proposed combined method.

### IX. CONCLUSION

The proposed combination of Split Bregman's total variation denoising algorithm with wavelet domain thresholding is easy to implement and effective method for the removal of Gaussian noise. This method is

outperforming in removing noise while keeping edge information and other details very well. This hybrid method is a solution for medical image denoising with fine edge information. Hence, it is concluded that it can be a better solution of TV minimization denoising in wavelet domain.

### ACKNOWLEDGMENT

We want to thank to our institute Technocrat Institute of Technology and faculty members of electronics and communication department for their helpful comments and suggestions. Kriti Shukla would like to acknowledge Prof. Vikas Gupta for his valuable discussions and guidance.

### REFERENCES

- [1] S. Li, and G. Zhao; "De-Noising of ECG Signal Using Translation Invariant Wavelet De-Noising Method with Improved Thresholding". 27th Annual International Conference of the Engineering in Medicine and Biology Society, IEEE-EMBS, pp. 5946-5949, 2005.
- [2] F. Luisier, T. Blu, and M. Unser. (2007) "A new sure approach to image denoising: Interscale Orthonormal Wavelet Thresholding" *IEEE Trans. Image Process.*, 16(3), pp. 593-606.
- [3] D. L. Donoho, and I. M. Johnstone, (1995) "De-noising by soft thresholding," *IEEE Trans. Inform. Theory*, 41, pp. 613-627.
- [4] D. L. Donoho, and I. M. Johnstone, (1995) "Adapting to unknown smoothness via wavelet shrinkage," *J. Amer. Statist. Assoc.*, 90(432), pp. 1200-1224.
- [5] L. Rudin, S. Osher, and E. Fatemi, (1992) "Nonlinear total variation based noise removal algorithms," *Physica D*, 60, pp. 259-268.
- [6] M. C. Motwani, M. C. Gadiya, R. C. Motwani, and F. C. Harris, Jr. "Survey of Image Denoising Techniques," *Proc. of GSPx 2004*, Santa Clara Convention Center, Santa Clara, CA, pp. 27-30, 2004.
- [7] D. L. Donoho, and I. M. Johnstone, (1994) "Ideal Spatial Adaptation by Wavelet Shrinkage," *Biometrika*, 81(3), pp. 425-455.
- [8] Y. Yu, and S. T. Acton, (2002) "Speckle reducing anisotropic diffusion," *IEEE Trans. Image Process.*, 11, pp. 1260-1270.
- [9] P. Coupe, P. Hellier, C. Kervrann and C. Barillot, (2009) "Nonlocal meansbased speckle filtering for ultrasound images," *IEEE Trans Image Process.*, 18, 2221-2229.
- [10] Y. Wang, J. Yang, W. Yin, and Y. Zhang, "A new alternating minimization algorithm for total variation image reconstruction," *SIAM J. Image Sci.*, 1(3), pp. 248-272, 2008.
- [11] S. Chang, B. Yu, and M. Vetterli, (2000) "Adaptive wavelet thresholding for image denoising and compression," *IEEE Trans. Image Process.*, 9, pp.1532-1546.
- [12] Tom Goldstein, Stanley Osher, "The Split Bregman Method For L1 Regularized problems".
- [13] Y Wang, W Yin, and Y Zhang. "A fast algorithm for image deblurring with total variation regularization". CAAM Technical Reports, 2007.
- [14] Curtis R. Vogel and Mary E. Oman. "Fast, Robust Total Variation- Based Reconstruction of Noisy, Blurred Images," *IEEE Trans. image process.* vol.7, no.6, pp.813-823, June 1998.
- [15] Y. Li and F. Santosa, "A computational algorithm for minimizing total variation in image restoration," *IEEE Trans. Image Processing*, vol. 5, pp. 987-995, 1996.
- [16] W Yin, S Osher, D Goldfarb, and J Darbon, "Bregman iterative algorithms for l1-minimization with applications to compressed sensing". *Siam J. Imaging Science*, 1:142{168, 2008.
- [17] D. Dobson and C. R. Vogel, "Convergence of an iterative method for total variation denoising," to appear in *SIAM J. Numer. Anal.*, available from [http://www.math.montana.edu/\\_vogel](http://www.math.montana.edu/_vogel).

- [18] Chan, T.F., Osher, S., and Shen, J.: "The digital TV filter and nonlinear denoising", IEEE Trans. Image Process., 2001, 10, (2), pp. 231-241
- [19] P.C.Hansen, Regularization tool: "A Matlab package for the analysis and solution of discrete ill-posed problems. Numerical Algorithms", 6:1-35, 1994.
- [20] J.G.Nagy and D.P.O'Leary. "Fast iterative image restoration with a specially variant PSF," In F.T.Luk, editor, Advanced signal Processing Algorithms, Architectures, and Implementations VII, vol. 3162, pages 388-399. SPIE, 1997.
- [21] David Strong<sup>1</sup> and Tony Chan<sup>2</sup> " Edge-preserving and scale-dependent properties of total variation regularization", INSTITUTE OF PHYSICS PUBLISHING, Inverse Problems 19 (2003) S165-S187, Online at stacks.iop.org/IP/19/S165, Nov 2003
- [22] L.Sendur, I.W Selesnick, "Bivariate shrinkage functions for wavelet based denoising exploiting interscale dependency," IEEE Trans. Signal Process.vol.50, pp.2744-2754, 2002.
- [23] Lysaker, M., Lundervold, A., and Tai, X.-C.: "Noise removal using fourth-order partial differential equation with applications to medical magnetic resonance images in space and time", IEEE Trans. Image Process., 2003, 12, (12), pp. 1579-1590

## **AUTHOR'S PROFILE**

### **Prof. Vikas Gupta**

Email ID: vgup24@yahoo.com

Born on July 24, 1979 in India has completed his bachelor degree from Rajeev Gandhi Proudyogiki Vishwavidyalaya, Bhopal(M.P.) India in 2002. He completed his M.Tech. in 2007 in the field of electronics and communication from Maulana Azad National Institute of Technology, Bhopal (M.P.), India. Presently he is pursuing his PhD degree from Maulana Azad National Institute of Technology, Bhopal (M.P.), India. His major field of interest is image processing.

He has published more than 20 research papers with his 10 years of teaching experience. Currently he is providing his service as head of department, E&C to Technocrats Institute of Technology, Bhopal affiliated to Rajeev Gandhi Technical University, Bhopal (M.P.), India.



### **Mrs. Kriti Shukla**

Email ID: kritiec23@gmail.com

Born on 17 December 1986, has completed her degree of bachelor of technology in 2007 from Utter Pradesh Technical university, Lucknow (U.P.) and pursuing her master's in technology in electronics and communication, from Technocrats Institute of

Technology, Bhopal (M.P.), affiliated to R.G.T.U. Bhopal (M.P.) India.