

DPFC System for Realizing Active Power Flow Control on Existing Power Lines

Carmel Tensy Pereira
PG Student, Department of
EEE, VITAM College Of
Engineering, Visakhapatnam-
531 173
carnelee@gmail.com

Saikiran Kumar Sivakoti K.
Assistant Professor,
Department of EEE, VITAM
College Of Engineering,
Visakhapatnam- 531 173
sivakoti.kiran@gmail.com

Durga Syam Prasad
Associate. Professor and HOD,
Department of EEE, VITAM
College Of Engineering,
Visakhapatnam- 531 173
durgasyamprasadk@gmail.com

Indranil Saaki
Assistant Professor,
Department of EEE, Visaka
College Of Engineering.,
Visakhapatnam- 530 045
indranil.saaki@gmail.com

Abstract - The Distributed Power Flow Controller (DPFC) is a new device within the FACTS family. The DPFC consists of two types of converters that are in shunt and series connection with grids. The common dc link between the shunt and the series converters is eliminated. The active power exchange between the shunt and series converters that is through the common dc link in the UPFC, though the transmission line at the 3rd harmonic frequency. The redundancy of the series converters provides the high reliability of the system. The DPFC employs the distributed FACTS (D-FACTS) concept, which is to use multiple small-size single-phase converters instead of the one large-size three-phase series converter in the UPFC. The large number of series converters provides redundancy, thereby increasing the system reliability. As the D-FACTS converters are single-phase and floating with respect to the ground, there is no high-voltage isolation required between the phases.

The DPFC has the control capability for the adjustment of the line impedance, the transmission angle, and the bus voltage. In this project a control scheme to improve the performance of DPFC during a failure is first introduced. The principle and analysis of the DPFC performance are presented in MATLAB. The proposed technique in this project for DPFC is Double Vector technique. The corresponding design of the control scheme along with the simulated experimental results is presented.

Keyword - AC-DC power conversion, load flow control, power electronics, power semiconductor devices, power system control, and power-transmission control.

I. INTRODUCTION

THE GROWING demand and the aging of networks make it desirable to control the power flow in power-transmission systems fast and reliability [1]. The flexible ac-transmission system (FACTS) that is defined by IEEE as “a power-electronic-based system and other static equipment that provide control of one or more ac-transmission system parameters to enhance controllability and increase power-transfer capability” [2], and can be utilized for power-flow control. Currently, the unified power-flow control (UPFC) shown in Fig. 1, is the most powerful FACTS device, which can simultaneously control all the parameters of the system: the line impedance, the transmission angle, and bus voltage [3].

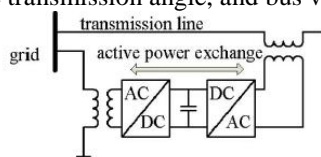

Fig. 1. Simplified representation of a UPFC.

The UPFC is the combination of a static synchronous compensator (STATCOM) and a static synchronous series compensator (SSSC), which are coupled via a common dc link, to allow bidirectional flow of active power between the series output terminals of the SSSC and the shunt output terminals of the STATCOM [4]. The converter in series with the line provides the main function of the UPFC by injecting a four-quadrant voltage with controllable magnitude and phase. The injected voltage essentially acts as a synchronous ac-voltage source, which is used to vary the transmission angle and line impedance, thereby independently controlling the active and reactive power flow through the line. The series voltage results in active and reactive power injection or absorption between the series converter and the transmission line. This reactive power is generated internally by the series converter (see e.g., SSSC [5]), and the active power is supplied by the shunt converter that is back-to-back connected. The shunt converter controls the voltage of the dc capacitor by absorbing or generating active power from the bus; therefore, it acts as a synchronous source in parallel with the system. Similar to the STATCOM, the shunt converter can also provide reactive components for the bus.

The components of the UPFC handle the voltages and currents with high rating; therefore, the total cost of the system is high. Due to the common dc-link inter connection; a failure that happens at one converter will influence the whole system. To achieve the required reliability for power systems, bypass circuits and redundant backups (back up transformer) are needed, which on other hand increase the cost. Accordingly, the UPFC has not been commercially used, even though, it has the most advanced control capabilities.

This paper introduces a new concept, called Distributed power-flow controller (DPFC) that is derived from the UPFC. The same as the UPFC, the DPFC is able to control all system parameters. The DPFC eliminates the common dc link between the shunt and the series converters. The active power exchange between the shunt and the series converter is through the transmission line at the third-harmonic frequency. The series converter of the DPFC employs the distributed FACTS

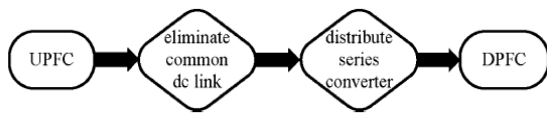

Fig. 2. Flowchart from UPFC to DPFC.

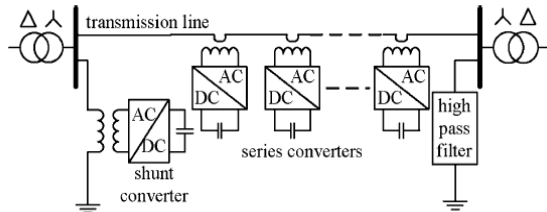

Fig. 3. DPFC configuration.

(D-FACTS) concept [6]. Comparing with the UPFC the DPFC have two major advantages: 1) low cost because of the low-voltage isolation and the low component rating of the series converter and 2) high reliability because of the redundancy of the series converters. This paper begins with presenting the principle of the DPFC, followed by its steady-state analysis. After a short introduction of the DPFC control, the paper ends with the experimental results of the DPFC.

II. DPFC PRINCIPLE

Two approaches are applied to the UPFC to increase the reliability and to reduce the cost; they are as follows. First, eliminating the common dc link of the UPFC and second distributing the series converter, as shown in fig.2. By combining these two approaches, the new FACTS device-DPFC is achieved.

The DPFC consists of one shunt and several series-connected converters. The shunt converter is similar as a STATCOM, while the series converter employs the D-FACTS concept, which is to use multiple single-phase converters instead of one large rated converter. Each converter within the DPFC is independent and has its own dc capacitor to provide the required dc voltage. The configuration of the DPFC is shown in Fig. 3. As shown, besides the key components, namely the shunt and series converters, the DPFC also requires a high-pass filter that is shunt connected at the other side of the transmission line, and to Y-Δ transformers at each side of the line. The reason for these extra components will be explained later.

The unique control capability of the UPFC is given by the back-to-back connection between the shunt and series converters, which allows the active power to exchange freely. To ensure that the DPFC have the same control capability as the UPFC, a method that allows the exchange of active power between converters with eliminated dc link is the prerequisite.

A. Eliminate DC link:

Within the DPFC, there is a common connection between the ac terminals of the shunt and series converters, which is the transmission line. Therefore, it is possible to exchange the active

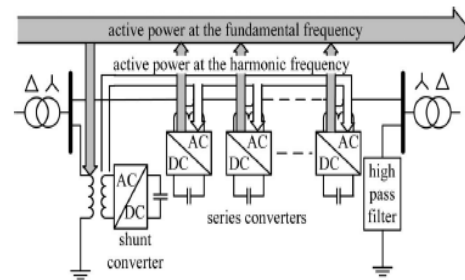

Fig. 4. Active power exchange between DPFC converters.

power through the ac terminals of the converters. The method is based on the power theory of non sinusoidal components. According to the Fourier analysis, a non sinusoidal voltage and current can be expressed by the sum of the sinusoidal functions in different frequencies with different amplitudes. The active power resulting from this non sinusoidal voltage and current is defined as the mean value of the product of voltage and current. Since the integrals of all the cross product of terms with different frequencies are zero, the active power can be expressed by

$$P = \sum_{i=1}^{\infty} V_i I_i \cos \Phi_i \quad (1)$$

Where V_i and I_i are the voltage and current at the i^{th} harmonic frequency, respectively, and Φ_i is the corresponding angle between the voltage and current. Equation (1) describes that the active power at different frequencies is isolated from each other and the voltage or current in one frequency has no influence on the active power at other frequencies. The independency of the active power at different frequencies gives the possibility that a converter without power source can generate active power at one frequency and absorb this power from other frequencies.

By applying this method to the DPFC, the shunt converter can absorb active power from the grid at the fundamental frequency and inject the current back into the grid at a harmonic frequency. This harmonic current will flow through the transmission line. According to the amount of required active power at the fundamental frequency, the DPFC series converters generate a voltage at the harmonic frequency, thereby absorbing the active power from harmonic components. Assuming a lossless converter, the active power generated at fundamental frequency is equal to the power absorbed from the harmonic frequency. For a better understanding, Fig. 4 indicates how the active power exchanges between the shunt and the series converters in the DPFC system.

The high-pass filter within the DPFC blocks the fundamental frequency components and allows the harmonic components to pass, thereby providing a return path for the harmonic components. The shunt and series converters, the high-pass filter, and the ground form the closed loop for the harmonic current. Due to the unique characters of third-harmonic frequency components, the third harmonic is selected to exchange the active power in the DPFC. In a three-phase system, the third harmonic in

each phase is identical, which is referred to as “zero-sequence”. The zero-sequence harmonic can be naturally

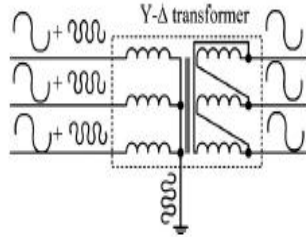

Fig.5. Utilize grounded Y-Δ transformer to provide path for the zero – sequence third harmonic.

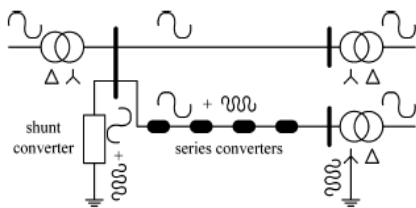

Fig.6. Route the harmonic current by using the grounding status of the Y-Δ transformer.

Blocked by Y-Δ transformers, which are widely used in power system to change voltage level. Therefore, there is no extra filter required to prevent the harmonic leakage to the rest of the network. In addition, by using the third harmonic, the costly high-pass filter, as shown in Fig. 4, can be replaced by a cable that is connected between the neutral point of the Y-Δ transformer on the right side in Fig. 3 and the ground. Because the Δ winding appears open circuit to the third-harmonic current, all harmonic current will flow through the Y winding and concentrate to the grounding cable, as shown in Fig. 5. Therefore, the large-size high-pass filter is eliminated.

Another advantage of using third harmonic to exchange active power is that the way of grounding of Y-Δ transformers can be used to route the harmonic current in a meshed network. If the branch requires the harmonic current to flow through the neutral point of the Y-Δ transformer at the other side in that branch will be grounded and *vice-versa*. Fig. 6 demonstrates a simple example of routing the harmonic current by using a grounding Y-Δ transformer. Because the transformer of the line without the series converter is floating, it is open circuit for third-harmonic components. Therefore, no third-harmonic current will flow through the line.

Theoretically, the third-, sixth-, and ninth-harmonic frequencies are all zero-sequence, and can be used to exchange active power in the DPFC. As it is well known, the capacity of a transmission line to deliver power depends on its impedance. Since the transmission-line impedance is inductive and proportional to the frequency, high-transmission frequencies will cause high impedance. Consequently, the zero-sequence harmonic with the lowest frequency-third harmonic is selected.

B. Distributed Series Converter

The D-FACTS is a solution for the series-connected FACTS, which can be dramatically reduce the total cost

and increase the reliability of the series FACTS device. The idea of the D-FACTS

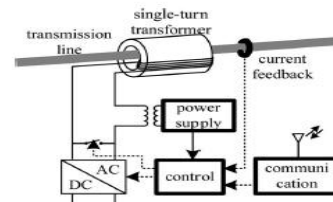

Fig. 7. D-FACTS unit configuration [7]

is to use a large number of controllers with low rating instead of one large rated controller. The small controller is a single-phase converter attached to transmission lines by a single-turn transformer. The converters are hanging on the line so that no costly high-voltage isolation is required. The single-turn transformer uses the transmission line as the secondary winding, inserting controllable impedance into the line directly. Each D-FACTS module is self-powered from the line and controlled remotely by wireless or power-line communication (see Fig. 7).

The structure of the D-FACTS results in low cost and high reliability. As D-FACTS units are single-phase devices floating on lines, high-voltage isolations between phases are avoided. The unit can easily be applied at any transmission-voltage level, because it does not require supporting phase-ground isolation. The power and voltage rating of each unit is relatively small. Further, the units are clamped on transmission lines, and therefore, no land is required. The redundancy of the D-FACTS provides an uninterrupted operation during a single module failure, thereby giving a much higher reliability than other FACTS devices.

C. DPFC Advantages

The DPFC can be considered as a UPFC that employs the D-FACTS concept and the concept of exchanging power through harmonic. Therefore, the DPFC inherits all the advantages of the UPFC and the D-FACTS, which are as follows.

1. High control capability: The DPFC can simultaneously control all the parameters of the power system: the line impedance, the transmission angle, and the bus voltage. The elimination of the common dc link enables separated installation of the DPFC converters. The shunt and series converters can be placed at the most effectively location. Due to the high control capability, the DPFC can also be used to improve the power quality and the system stability, such as low-frequency power oscillation damping [8], voltage sag restoration, or balancing asymmetry.

2. High reliability: The redundancy of the series converter gives an improved reliability. In addition, the shunt and series converters are independent, and the failure at one place will not influence the other converters. When a failure occurs in the series converter, the converter will be short-circuited by bypass protection, thereby having little influence to the network. In the case of the shunt converter

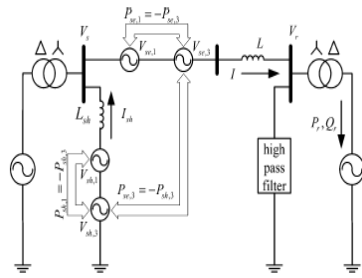

Fig. 8. DPFC simplified representation

failure, the shunt converter will trip and the series converter will stop providing active compensation and will act as the D-FACTS controller [9].

3. *Low cost.* There is no phase-to-phase voltage isolation required by the series converter. Also, the power rating of each converter is small and can be easily produced in series production lines. However, as the DPFC injects extra current at the third-harmonic frequency into the transmission line and transformer should be aware of.

III. ANALYSIS OF THE DPFC

In this section, the steady-state behaviour of the DPFC is analysed, and the control capability of the DPFC is expressed in the parameters of the network and the DPFC.

To simplify the DPFC, the converters are replaced by controllable voltage sources in series with impedance. Since each converter generates the voltage at two different frequencies, it is represented by two series-connected controllable voltage sources, one at fundamental frequency and the other at the third-harmonic frequency. Assuming that the converters and the transmission line are lossless, the total active power generated by the two frequency voltage sources will be zero. The multiple series converters are simplified as one large converter with the voltage, which is equal to the sum of the voltages for all series converter, as shown in Fig. 8.

In Fig. 8, the DPFC is placed in a two-bus system with the sending-end and the receiving-end voltages V_s and V_r , respectively. The transmission line is represented by an inductance L with the line current I . The voltage injected by all the DPFC series converters is $V_{se,1}$ and $V_{se,3}$ at the fundamental and the third-harmonic frequency, respectively. The shunt converter is connected to the sending bus through the inductor L_{sh} and generates the voltage $V_{sh,1}$ and $V_{sh,3}$; the current injected by the shunt converter is I_{sh} . The active and reactive power flow at the receiving end is P_r and Q_r , respectively. This representation consists of both the fundamental and third-harmonic frequency components. Based on the superposition theorem, the circuit in Fig. 8 can be further simplified by being split into two circuits at different frequencies. The two circuits are isolated from each other, and the link between these.

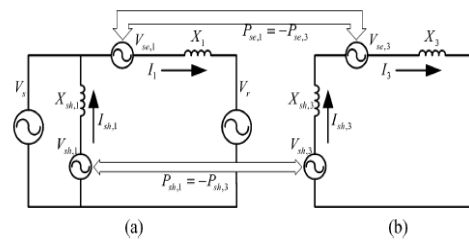

Fig. 9. DPFC equivalent circuit. (a) Fundamental Frequency. (b) Third-Harmonic Frequency.

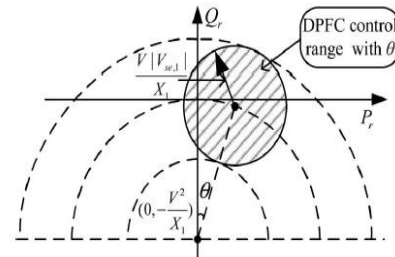

Fig. 10. DPFC active and reactive power control range with the transmission angle

circuits is the active power balance of each converter, as shown in Fig. 9.

The power-flow control capability of the DPFC can be illustrated by the active power P_r and reactive power Q_r received at the receiving end. Because the DPFC circuit at the fundamental frequency behaves the same as that of the UPFC, the active and reactive power flow can be expressed as follows [1]:

$$(P_r + P_{ro})^2 + (Q_r - Q_{ro})^2 = \left(\frac{|V| |V_{se,1}|}{X_1} \right)^2 \quad (2)$$

Where P_{ro} , Q_{ro} , and θ are the active, reactive power flow, and the transmission angle of the uncompensated $X_{se,1} = \omega L_{se}$ is the line impedance at fundamental frequency, and $|V|$ is the voltage magnitude at both ends. In the PQ -plane, the locus of the power flow without the DPFC compensation $f(P_{ro}, Q_{ro})$ is a circle with the radius of $|V|^2 / |X_1|$. Each point of this circle gives the P_{ro} and Q_{ro} values of the uncompensated system at the corresponding transmission angle θ . The boundary of the attainable control range for P_r and Q_r is obtained from a complete rotation of the voltage $V_{se,1}$ with its maximum magnitude. Fig. 10 shows the control range of the DPFC with the transmission angle θ .

To ensure the series converters to inject a 360° rotatable voltage, an active and reactive power at the fundamental frequency is required. The reactive power is provided by the series converter locally and the active power is supplied by the shunt converter. This active power requirement is given

$$P_{se,3} = \text{Re}(V_{se,3} I_3^*) = \frac{X_3}{|V_r|^2} |S_r| |S_{r,3}| \sin(\varphi_{r,3} - \varphi_r) \quad (3)$$

where $\varphi_{r,3}$ is the power angle at the receiving end of the uncompensated system, which equals $\tan^{-1}(P_{ro}/Q_{ro})$ and $\varphi_{r,3}$ is

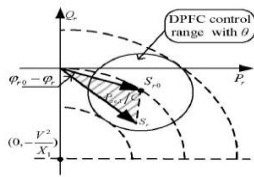

Fig. 11. Relationship between $P_{se,1}$ and the power flow at the receiving end.

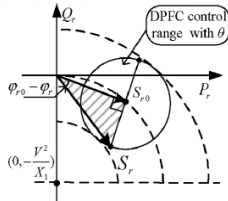

Fig. 12. Maximum active power requirement of the series converters.

The power angle at receiving end with the DPFC compensation. The line impedance X_1 and the voltage magnitude $|V_r|$ are constant; therefore, the required active power is proportional to $|S_r| |S_{r0}| \sin(\phi_{r0} - \phi_r)$, which is two times the area of the triangle that is formed by the two vectors S_{r0} and S_r . Fig. 11 illustrates the relationship between $P_{se,1}$ and the power flow at the receiving end at a certain power angle θ .

Consequently, the required active power by the series converter can be written as follows:

$$P_{se,1} = CA_{(e,r,0,r)} \quad (4)$$

Where the coefficient $C = 2X_1 / |V_r|^2$ and $A_{(0,r,0,r)}$ is the area of the triangle $(0, S_{r0}, S_r)$. The angle difference $\phi_{r0} - \phi_r$ can be positive or negative, and the sign gives the direction of the active power through the DPFC series converters. The positive sign means that the DPFC series converters generate active power at the fundamental frequency and vice versa. The active power requirement varies with the controlled powerflow, and the active power requirement has its maximum when the vector $S_r - S_{r0}$ is perpendicular to the vector S_{r0} , as shown in Fig.12.

According to Fig.12, the relationship between the powerflow control range and the maximum active power requirement can be represented by

$$P_{se,1,max} = \frac{|X_1| |S_{r0}|}{|V_r|^2} |S_{r,c}| \quad (5)$$

where $|S_{r,c}|$ is the control range of the DPFC.

Each converter in the DPFC generates two frequency voltages at the same time. Accordingly, the voltage rating of the each converter should be the sum of the maximum voltage of the two

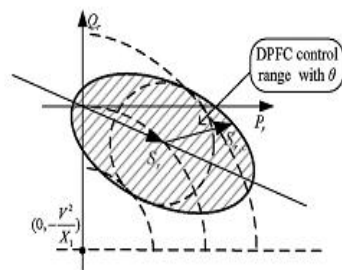

Fig. 13. DPFC power-flow control range frequencies component.

$$V_{se,max} = |V_{se,1,max}| + |V_{se,3,max}| \quad (6)$$

During the operation, the active power requirement of the series converter varies with the voltage injected at the fundamental frequency. When the requirement is low, the series voltage at the third-harmonic frequency will be smaller than $|V_{se,3,max}|$. This potential voltage that is between $V_{se,3}$ and $|V_{se,3,max}|$ can be used to control the powerflow at the fundamental frequency, thereby increasing the power-flow control region of the DPFC, when $S_{r,e}$ is perpendicular to the uncompensated power S_{r0} , the series converters require maximum active power, and the radius of the DPFC control region is given by

$$|S_{r,c}| = \frac{|V_r| |V_{se,1,max}|}{X_1} \quad (7)$$

If $S_{r,e}$ is in the same line as S_{r0} , the series converters only provide the reactive compensation and the boundary of the DPFC control region will extend to

$$|S_{r,c}| = \frac{|V_r| |V_{se,1,max}| + |V_{se,3,max}|}{X_1} \quad (8)$$

It shows that the control region of the DPFC can be extended to a shape that is similar as an ellipse, as shown in Fig.13.

To obtain the same control capability as the UPFC, the rating of the DPFC converter at the fundamental frequency should be the same as the one for the UPFC. Because the voltages and currents at the third-harmonic frequency have to be added, the rating of the DPFC converter is slightly larger than the UPFC. The increased rating is related with the active power exchanged at the third-harmonic frequency. For a transmission line, the line impedance $|X_1|$ is normally around 0.05 p.u. (per unit). Assuming the bus voltages $|V|$ and uncompensated power flow $|S_{r0}|$ is 1 p.u., and then, from (7), we can see that to control 1-p.u. power flow, the exchanged active power is around 0.05 p.u. power flow, the exchanged active power is around 0.05 p.u.

Even with this extra voltage and current at the third-harmonic frequency, the cost of the DPFC is still much lower than the UPFC, for the following reasons: 1) the UPFC converter handles the line-to-line voltage isolation that is much larger than voltage injected by the series converter; 2) no land requirement for the series converter; and 3) the active and passive components for the DPFC converter are low-voltage components (less than

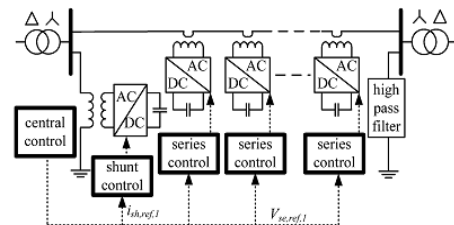

Fig. 14. DPFC control block diagram.

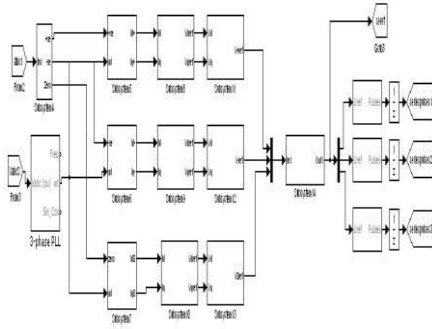

Fig. 15. Block diagram of the series converter control. (1 kv and 60 A), which is much cheaper than the high-voltage components in the UPFC.

IV. DPFC CONTROL

To control the multiple converters, DPFC consists of three types of controllers; they are central controller, shunt control, and series control, as shown in Fig. 14. The shunt and series control are local controllers and are responsible for maintaining their own converters parameters. The central control takes account of the DPFC functions at the power-system level. The function of each controller is listed next.

A. Central Control

The central control generates the reference signals for both the shunt and series converters of the DPFC. It is focused on the DPFC tasks at the power-system level, such as power-flow control, low-frequency power oscillation damping, and balancing of asymmetrical components. According to the system requirement, the central control gives corresponding voltage-reference signals for the series converters and reactive current signal for the shunt converter. All the reference signals generated by the central control are at the fundamental frequency.

B. Series Control

Each series converter has its own series control. The controller is used to maintain the capacitor dc voltage of its own converter by using the third-harmonic frequency components and to generate series voltage at the fundamental frequency that is prescribed by the central control.

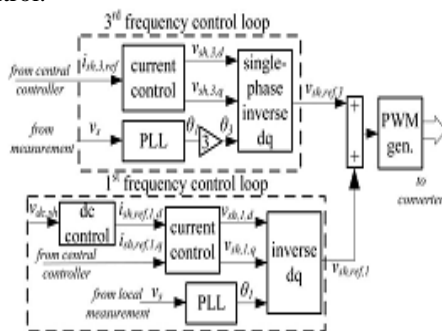

Fig. 16. Block diagram of the shunt converter control.

The third-harmonic frequency control is the major control loop with the DPFC series converter control. The principle of the vector control is used here for the dc-

voltage control [10]. The third-harmonic current through the line is selected as the rotation reference frame for the single-phase park transformation, because it is easy to be captured by the phase-locked loop(PLL).[11] in the series converter. As the line current contains two frequency components, a third high-pass filter is needed to reduce the fundamental current. The d-component of the third-harmonic voltage is the parameter that is used to control the dc-voltage, and its reference signal is generated by the dc-voltage control loop. To minimize the reactive power that is caused by the third harmonic, the series converter is controlled as a resistance at the third-harmonic frequency. The q-component of the third-harmonic voltage is kept zero during the operation.

As the series converter is single-phase, there will be voltage ripple at the dc side of each converter. The frequency of the ripple depends on the frequency of the current that flows through the converter. As the current contains the fundamental and third-harmonic frequency component, the dc-capacitor voltage will contain 100-, 200-, and 300-Hz frequency component [12],[13]. There are two possible ways to reduce this ripple. One is to increase the turn ratio of the single-phase transformer of the series converter to reduce the magnitude of the current that flows into the converter. The other way is to use the dc capacitor with a larger capacitance.

C. Shunt Control

The block diagram of the shunt converter control is shown in Fig. 16. The objective of the shunt control is to inject a constant third-harmonic current into the line to provide active power for the series converters. The third-harmonic current is locked with the bus voltage at the fundamental frequency. A PLL is used to capture the bus-voltage frequency, and the output phase signal of the PLL is multiplied by three to create a virtual rotation reference frame for the third-harmonic component. The shunt converter's fundamental frequency control aims to inject a controllable reactive current to grid and to keep the capacitor dc voltage at a constant level. The control for the fundamental frequency components consists of two cascaded controllers. The current control is the inner control loop, which is to modulate the shunt current

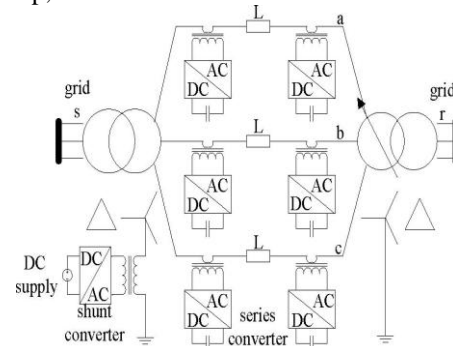

Fig.17. DPFC experimental setup circuit

At the fundamental frequency. The q-component of the reference signal of the shunt converter is obtained from the central controller, and d-component is generated by the dc control.

V. SIMULATION RESULTS

An Simulation setup has been built to verify the principle and control of the DPFC. One shunt converter and six-singe phase series converters are built and tested in a scaled network, as shown in Fig. 1-7. Two isolated buses with phase difference are connected by the line. Within the experimental setup, the shunt converter is a single-phase inverter that is connected between the neutral point of the Y-Δ transformer and the ground. The inverter is powered by a constant dc-voltage source. The specifications of the DPFC experimental setup are listed in the Appendix (see Table 1).

Within the setup, multiple series converters are controlled by a central controller. The central controller gives the reference voltage signals for all series converters. The voltages and currents with in the setup are measured by an oscilloscope and processed in computer by using MATLAB. The photograph of the DPFC experimental setup is illustrated in Fig. 1-8.

To verify the DPFC principle, two situations are demonstrated: the DPFC behaviour in steady state and the step response. In steady state , the series converter is controlled to insert a voltage vector with both d- and q-component, which is $V_{se,q,ref} = -0.1V$. Figs. 1-8 show one operation point of the DPFC setup. For clarity, only the waveforms in one phase are shown. The voltage injected by the Series converter, the current through the line, and the voltage and current at the Δ side of the transformer are illustrated. Design using MATLAB. To analyze the voltage and current at the fundamental frequency, the measured data that contains harmonic distortion are filtered by a low-pass digital filter with 50-Hz cut-off frequency. Because of this filter, the calculated voltage and current at the fundamental frequency have a 1.5 cycle delay to the actual values

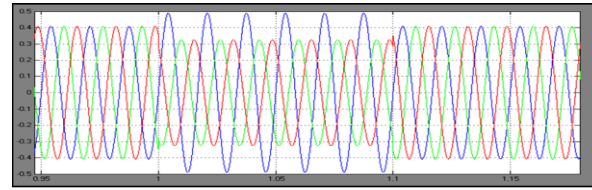
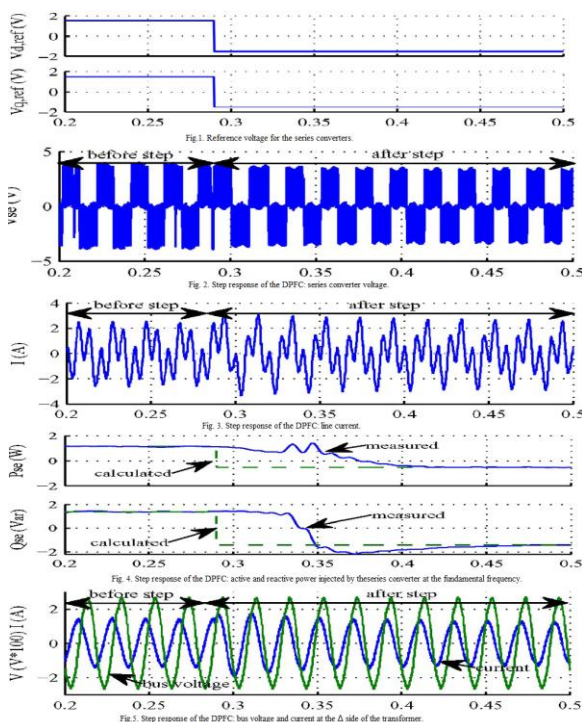

Figure 7: Three-phase current at the delta side of a transformer.

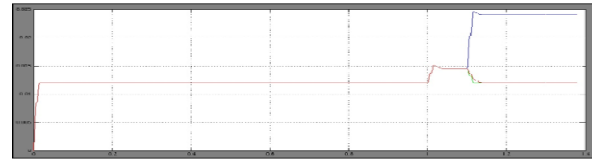

Figure 8: Reference signals for the series converters in three phases.

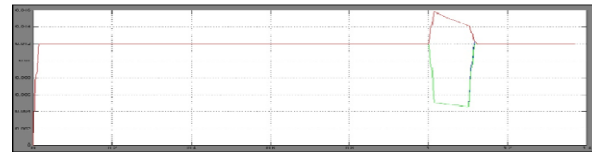

Figure 9: The magnitude of the voltage injected by all series converters.

Thereby causing a delay of the measured active and reactive power. Fig 4 illustrated the active and reactive power injected by the series converter. A comparison is made between the measured power and the calculated power. We can see that the series converters are able to absorb and inject both active and reactive power to the grid at the fundamental frequency.

VI. CONCLUSION

This paper has presented a new concept called DPFC. The DPFC emerges from the UPFC and inherits the control capability of the UPFC, which is simultaneous adjustment of the line impedance, the transmission angle, and the bus-voltage magnitude. The common dc link between the shunt and series converters, which is used for exchanging active power in the UPFC, is eliminated. This power is now transmitted through the transmission line at the third-harmonic frequency. The series converter of the DPFC employs the D-FACTS concept, which uses multiple small single-phase converters instead of one large-size converter. The reliability of the DPFC is greatly increased because of the redundancy of the series of the series converters. The total cost of the DPFC is also much lower than the UPFC, because no high-voltage isolation is required at the series-converter part and the rating of the components of is low. The DPFC concept has been verified by an experimental setup. It is proved that the shunt and series converters in the DPFC can exchange active power at the third-harmonic frequency, and the series converters are able to inject controllable active and reactive power at the fundamental frequency.

REFERENCES

- [1] Y.H. Song and A. Johns, *Flexible ac Transmission Systems (FACTS)* (IEE Power and Energy Series), vol. 30. London, U.K.: Institution of Electrical Engineers, 1999.
- [2] N. G. Hingorani and L. Gyugyi, *Understanding FACTS : Concepts and Technology of Flexible AC Transmission Systems*. New York: IEEE Press, 2000. 2572 IEEE TRANSACTIONS

ON POWER ELECTRONICS, VOL. 25, NO. 10, OCTOBER 2010

- [3] L. Gyugyi, C.D. Schauder, S. L. Williams, T. R. Rietman, D. R. Torgerson, and A. Edris, "The unified power flow controller: A new approach to power transmission control," *IEEE Trans. Power Del.*, vol. 10, no. 2, pp. 1085–1097, Apr. 1995.
- [4] A. A. Edris, "Proposed terms and definitions for flexible ac transmission system (facts)," *IEEE Trans. Power Del.*, vol. 12, no. 4, pp. 1848–1853, Oct. 1997.
- [5] K. K. Sen, "Sssc-static synchronous series compensator: Theory, modeling, and application," *IEEE Trans. Power Del.*, vol. 13, no. 1, pp. 241–246, Jan. 1998.
- [6] M. D. Deepak, E. B. William, S. S. Robert, K. Bill, W. G. Randal, T. B. Dale, R. I. Michael, and S. G. Ian, "A distributed static series compensator system for realizing active power flow control on existing power lines," *IEEE Trans. Power Del.*, vol. 22, no. 1, pp. 642–649, Jan. 2007.
- [7] D. Divan and H. Johal, "Distributed facts—A new concept for realizing grid power flow control," in *Proc. IEEE 36th Power Electron. Spec. Conf. (PESC)*, 2005, pp. 8–14.
- [8] Y. Zhihui, S.W. H. de Haan, and B. Ferreira, "Utilizing distributed power flow controller (dpfc) for power oscillation damping," in *Proc. IEEE Power Energy Soc. Gen. Meet. (PES)*, 2009, pp. 1–5.
- [9] Y. Zhihui, S. W. H. de Haan, and B. Ferreira, "Dpfc control during shunt converter failure," in *Proc. IEEE Energy Convers. Congr. Expo. (ECCE)*, 2009, pp. 2727–2732.
- [10] Y. Sozer and D. A. Torrey, "Modeling and control of utility interactive inverters," *IEEE Trans. Power Electron.*, vol. 24, no. 11, pp. 2475–2483, Nov. 2009.
- [11] L. Huber, B. T. Irving, and M. M. Jovanovic, "Review and stability analysis of pll-based interleaving control of dcm/ccm boundary boost pfc converters," *IEEE Trans. Power Electron.*, vol. 24, no. 8, pp. 1992–1999, Aug. 2009.
- [12] M. Mohaddes, A. M. Gole, and S. Elez, "Steady state frequency response of statcom," *IEEE Trans. Power Del.*, vol. 16, no. 1, pp. 18–23, Jan. 2001. [13] N. Mohan, T. M. Undeland, and W. P. Robbins, *Power Electronics : Converters, Applications, and Design*, 3rd ed. Hoboken, NJ: Wiley, 2003.

AUTHOR'S PROFILE

Carmel Tensy Pereira

PG Student,
Department of EEE, VITAM College of Engineering,
Visakhapatnam- 531 173
carneleee@gmail.com

Saikiran Kumar Sivakoti K.

Assistant Professor,
Department of EEE, VITAM College of Engineering,
Visakhapatnam- 531 173
sivakoti.kiran@gmail.com

Durga Syam Prasad

Associate. Professor and HOD,
Department of EEE, VITAM College of Engineering,
Visakhapatnam- 531 173
durgasyamprasadk@gmail.com

Indranil Saaki

Assistant Professor,
Department of EEE, Visaka College of Engineering,
Visakhapatnam- 530 045
indranil.saaki@gmail.com