

Manipulator Arms by using Infrared Collision Avoidance System to Replace Human Interface for an Automated Prescription Dispensing System

Dr. Rafie Hamidpour, Ph.D., Sina Pourjabar, Roxanna Hamidpour, Sam Hamidpour

Abstract – A collision avoidance system for a manipulator arm such as a robot arm includes a plurality of infrared sources and sensors distributed about the periphery of a mounting block coupled with the assembly. Baffles prevent the sensors from receiving infrared light directly from the sources. The sensors are operable to produce sensor signals, received from an object in the field of view of the sensors, representative of source-derived reflected infrared light impinging thereon. A controller coupled with the sensors determines whether the sensor signals exceed a predetermined level indicative of an object in the field of view of the corresponding sensor and prevents movement toward the object in order to avoid a collision.

It has been noted that today's pharmacist is required to spend more time counseling customers as opposed to filling prescriptions. To offset this increase in consultation time, a technician is usually hired to reduce some of the pharmacist's tasks. This is likely to result in higher prescription drug prices for the consumer. There is, however, another option – automation! Automation equipment can reduce the pharmacist's work load, consequently freeing up time for counseling.

Keywords – Manipulator Arm, Collision, Collision Avoidance System, Biomedical Arm, Pharmaceutical Dispensing Technology.

I. INTRODUCTION FIELD OF THE DESIGN

The present design relates to the field of collision avoidance systems using infrared light for manipulator arms such as robot arms for automated prescription dispensing design can reduce the heavy loads of work for pharmacists for filling up the prescriptions and giving them more time for consultation and suggestion about the prescribed drugs and their effects.

II. DESCRIPTION OF THE PRIOR ART

The prior art discloses devices to prevent robots from colliding with one another. For example, U.S. Patent No. 4,028,533, discloses a robot having a head portion operable for sensing infrared rays emitted from other robots. This does nothing, however, to prevent a robot so equipped from colliding with another object that does not emit infrared light.

Other collision avoidance schemes for robots use infrared light to detect objects in only one direction, usually the direction of movement. This does not prevent collisions with objects in other directions.

III. SUMMARY OF THE DESIGN

The infrared collision avoidance system of the present design solves the problems of the prior art discussed above and provides a distinct advance in the state of the art. More particularly, the system hereof provides a practical means to avoid collisions between manipulator arms such as robot arms and nearby objects.

The preferred embodiment of the present design includes a plurality of infrared sources and infrared sensors alternately distributed about the periphery of a manipulator arm. Each sensor detects source-derived infrared light reflected from an object present in the field of view, and produces sensor signals in response. A controller, including a detection circuit, receives the sensor signals and determines whether the signals exceed a predetermined level and, in response, controls the movement of the arm to prevent a collision with the object. Other preferred aspects of the present design are discussed herein.

IV. BRIEF DESCRIPTION OF THE DRAWINGS

Figure 1 is a plan view of the preferred apparatus embodying the present design; it is positioned on a manipulator arm with the gripper assembly in the retracted position and showing the electrical components in block diagram form; Fig.2 is a partial perspective view of the apparatus of Fig. 1 showing the gripper assembly in the dispensing position;

Fig.3 is an above-ground view of the side of the infrared sources, sensors and mounting block of the apparatus of Fig. 1; Fig. 3 is an electrical schematic diagram of the detection circuit of Fig.1.

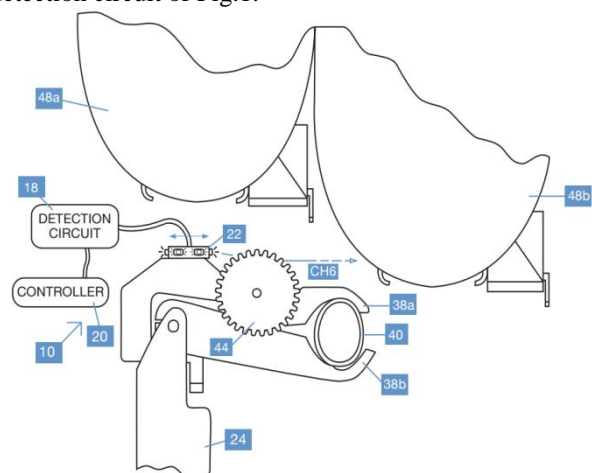

Fig.1. Gripper Design & Drawing by Dr. Rafie Hamidpour

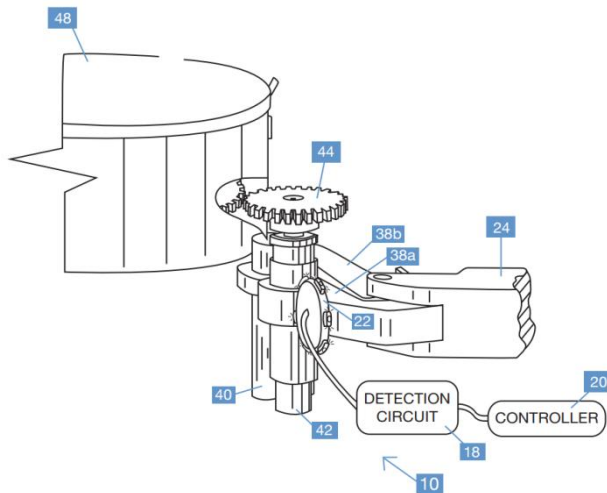

Fig.2. M. Arm Design & Drawing by Dr. Rafie Hamidpour

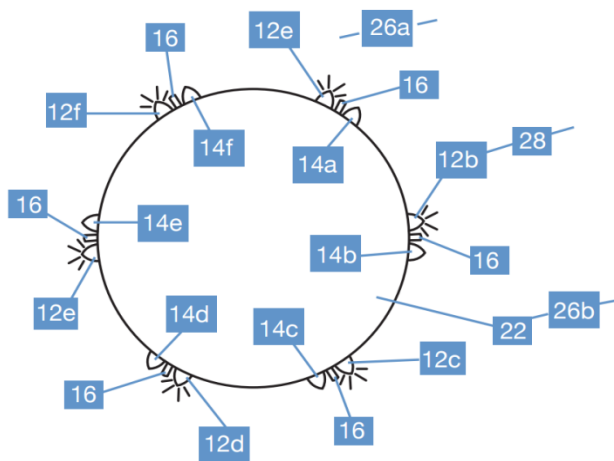

Fig.3. Sensor Design & Drawing by Dr. Rafie Hamidpour

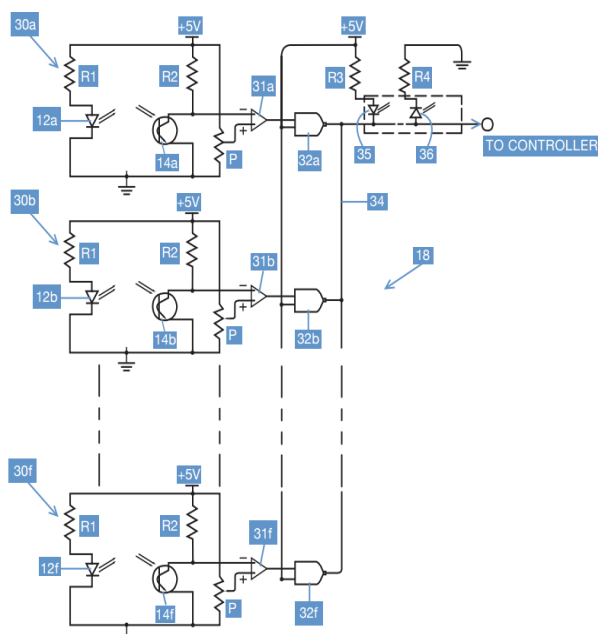

Fig.4. Circuit Design & Drawing by Dr. Rafie Hamidpour

V. DETAILED DESCRIPTION OF THE PREFERRED EMBODIMENT

Referring to the drawing figures, the preferred embodiment of the present design is shown as apparatus 10 and include six infrared sources 12, specifically designated 12a, 12b, 12c, 12d, 12e and 12f, six infrared sensors 14, specifically designated 14a, 14b, 14c, 14d, 14e and 14f, baffles 16, detection circuit 18, controller 20, cylindrical mounting block 22, coupling sources 12, sensors 14, and baffles 16 with manipulator assembly 23. Manipulator assembly 23 includes manipulator arm 24 and gripper assembly 25. Apparatus 10 can be advantageously used in a wide variety of applications including robot arms, such as that illustrated in U.S. Patent No. 5,337,919 incorporated herein by reference.

Infrared sources 12 are preferably light emitting diodes (type QEC113QT-ND) distributed equidistantly about the periphery of mounting block 22. Infrared sensors 14 are preferably phototransistors (type QSC113QT-ND) and are also distributed equidistantly in an alternating fashion, with sources 12 about the periphery of block 22 and thereby about the periphery of arm 24.

Baffles 16 project outward from the periphery of block 22 and are positioned between adjacent sources 12 and sensors 14 in order to prevent sensors 14 from receiving infrared light directly from sources 12. More particularly, baffles 16 restrict sensors 14 to receiving infrared light from sources 12 (source-derived light) as reflected light. As illustrated in Fig. 3, baffles 16 and the position of sensors 14 on block 22 define respective fields of view 26 for sensors 14. Fig. 3 illustrates fields of view 26a and 26b corresponding respectively to sensors 14a and 14b with the fields of view for the others being similarly configured. It is noted that fields of view 26a and 26b overlap to form an overlap zone 28. With the overlapping configuration, fields of view 26 cooperate to present a sensing plane.

Fig. 4 illustrates detection circuit 18 coupled with sources 12 for supplying power thereto and with sensors 14 for receiving sensor signals therefrom. Circuit 18 includes six identical sub-circuits 30 (only three of which are shown as 30a, 30b and 30f) connected respectively to one of the infrared sources 12 and to one of the infrared sensors 14 as illustrated. Each sub-circuit 30 receives 5 volts of power supplied from controller 20.

Each infrared source 12 receives operating power at the anode by the way of current limiting resistor R1 (270 ohms). The cathode of each source 12 is connected to ground. The collector of each infrared sensor 14 receives biasing current by the way of resistor R2 (10K ohms) with each sensor emitter connected to ground.

The collector of each sensor 14, as output, is connected to the negative input terminal of a respective comparator 31 (shown as comparators 31a, 31b and 31f in Fig. 4). As illustrated, respective potentiometers P supply individual reference voltages to the positive input terminals of comparators 31. The potentiometers are individually adjustable and define a threshold signal or sensitivity level for sensors 14. The outputs from comparators 31 are

connected respectively as inputs to NAND gates 32 (shown as gates 32a, 32b and 32f in Fig. 4). The other inputs to gates 32 are biased at logic high (+5 volts).

The outputs from gates 32 are connected in common on line 34 to the cathodes of light emitting diodes (LED) 35 and 36. Resistor R3 (330 ohms) is connected between supply voltage and the anode of LED 35. Resistor R4 (330 ohms) is connected between ground and the cathode of LED 36.

As described in the '919 patent, gripper assembly 25, under the control of controller 20, is pivotally coupled with arm 24 and is shiftable between a retracted or traveling position, as illustrated in Fig. 1, and a dispensing position, as illustrated in Fig. 2. Assembly 25 includes gripper fingers 38a and 38b, configured for grasping a vial 40, and motor 42 mounted to the outboard side of gripper finger 38a, with drive gear 44 connected to the output shaft of motor 42.

Mounting block 22 is connected to the outboard side of gripper 38. Each source 12 emits infrared light when activated and the distribution of sources 12 causes the light from these sources to overlap in sensing plane 46, which is parallel to the plane of movement of manipulator assembly 23. In the operational environment, as described in the '919 patent, medicament dispensers 48 are vertically disposed in rows of columns and, as such, the front faces of dispensers 48 define a dispenser plane. Dispensers 48a and 48b are illustrated in Fig. 1. Sensing plane 46 is parallel and spaced from the dispenser plane.

In operation, with detection circuit 18 energized, sources 12 emit infrared light. With manipulator assembly 23 in the retracted position and no object in the fields of view 26, sensors 14 receive no reflected infrared light from sources 12 and do not conduct. As a result, logic high signals (+5 volts) are presented to the negative input terminals of comparators 32. These logic high signals are above the adjustable reference (predetermined level) supplied by potentiometers P and the outputs from comparators 31 are logic low as supplied to NAND gates 32. With the other inputs being high, the outputs from gates 32 are also high, with LED 35 off and LED 36 on.

As an example of the operation of apparatus 10, Fig. 1 illustrates the presence of an object, dispenser 48b, in sensing plane 46 and more particularly, in the field of view 26b of sensor 14b. Such might occur if dispensers 48b were not properly replaced after replenishing with medicament. Infrared light emitted from source 12b, and perhaps other sources 12, would impinge on dispenser 48b and light therefrom would be reflected back to sensor 14b. Upon receiving this source-derived reflected infrared light, sensor 14b would conduct and present a logic low signal to comparator 31b. This low signal would be below the reference voltage and the output from comparator 31b would be logic high. In response, the output from NAND gate 32b would go logic low and sink current which activates LED 35 and turns off LED 36.

Controller 20 would also be supplied with this logic low signal on line 34, indicating the presence of an object in the field of view of one of sensors 14. Controller 20, coupled with detection circuit 18 and receiving the output

on line 34, would respond by preventing movement of manipulator assembly 23. This action would avoid a collision between assembly 23 and dispenser 48b. Other responses can also be initiated such as an alarm signal to alert an attendant to the problem.

If no object is encountered, controller 20 would move manipulator assembly 23 to a designated dispenser 48 for receiving medicament therefrom. Gripper assembly 25 then would rotate into the dispensing position as shown in Fig. 2. When this occurs, the sensing plane also would rotate and the presence of an object would be detected, in particular, the presence of the dispenser 48. In the preferred embodiment, controller 20 is programmed to ignore signals on line 34 when gripper assembly 25 is shifted to the dispensing position.

Those skilled in the art will appreciate that the present design encompasses many variations in the preferred embodiment described herein. For example, output devices could be coupled with each sub-circuit 30 so that the controller could determine which sensor is detecting the presence of an object. This would also enable the controller to determine whether an object was in the overlap area of adjacent sensors. With this additional information, the controller could determine a path of movement for the manipulator arm around the object. Those skilled in the art will also appreciate that the infrared red light emitted from sources 12 could be modulated or encoded and the infrared light detected by sensors 14 correspondingly filtered to prevent interference from other infrared sources. As a final example, the periphery of the mounting block could be configured so that either the sensors or sources were recessed thereby avoiding the need for baffles to prevent direct transmission of infrared light to the sensors.

VI. CONCLUSION

The reports of many studies about present automated prescription dispensing have provided a scientific validation for the collision avoidance system and our infrared collision avoidance system in automated dispensing drug devices provides a practical means to prevent collisions between manipulator arm such as robotic arm and nearby objects. The design incorporates the plurality of infrared sources and infrared sensors which alternately are distributed about the periphery of a manipulator arm. Each sensor detects source-derived infrared light, reflected from an object present in the field of view and in response, produces sensor signals. Baffles prevent the sensors from receiving infrared light directly from the sources. A controller, including a detection circuit, receives the sensor signals and determines whether the signals have exceeded a predetermined level and in response, controls the movement of the robotic arms to prevent a collision with the object.

This design offers a distinct advanced system compare to the prior designs and provides a practical means to solve the problem of collisions between manipulate arm and nearby objects. The use of the present automated prescription dispensing design can reduce the heavy loads

of work for pharmacists for filling up the prescriptions and giving them more time for consultation and suggestion about the prescribed drugs and their effects.

GUARANTOR

The corresponding author is a guarantor of the submission.

CONFLICT OF INTEREST

Authors declare no conflict of interest. Mr. Sina Pourjabar, Ms. Roxanna Hamidpour and Mr. Sam Hamidpour are Summer Interns.

REFERENCES

- [1] Armine, Harold T., Ritchey, John A., and Moodie, Coline L. (1987). *Manufacturing Organization and Management*, NJ: Prentice-Hall.
- [2] Barkakati, N. (1990). *The Waite Group-Microsoft Macro Assembler Bible*, Carmel, Indiana: Howard W. Sams & Company.
- [3] Cook, James (1984, October 8). Kanban, American-Style. *Forbes*. pp. 66⁺.
- [4] Craig, J. C. (1990). *Microsoft Quick C Programmer's Toolbox*. Redmond, WA: Microsoft Press.
- [5] Dorfman, John R. (1984, January 2). Kanban/ Can Do! *Forbes*, p. 113.
- [6] Funk, K D., Wagner, L. E., & Thompson, J. G. (1989). Real Time Data Acquisition and Control Techniques for Automated Testing. Submitted for presentation to the 1989 International ASAE winter Meeting.
- [7] Hayes, Robert H., & Wheelwright, Stephen C. (1984). *Restoring Our Competitive Edge*. NY: Wiley.
- [8] "How to Regain the Productive Edge," *Fortune*. 22 May 1989, pp. 92-94⁺.
- [9] Ishkawa, Kaoru. (1985). *What is Total Quality Control? The Japanese Way*. Englewood Cliffs: Prentice-Hall.
- [10] *Japanese Manufacturing Techniques*. (1982). NY: The Free Press.
- [11] "JIT Misunderstood," *Manufacturing Engineering* 101. November 1988, pp.22-23.
- [12] Keithley Metrabyte JASYST IDAC Handbook. (Vol. 23). (1990). Taunton, MA: Motion Control Engineering.
- [13] Lyones, Paul E. (1989, June 23). Shaving Inventory and Growing Responsive with JIT. *Quality Progress*. pp. 52-53.
- [14] *MC-200and MC-400 Motion Controllers Users Guide*. (1988). Santa Barbara, CA: Motion Engineering.
- [15] Mishne, Patricia. (1988, November). A Passion for perfection. *Manufacturing Engineering* 101. pp. 46-58.
- [16] Port, Otis. (1989, June 16). Back to Basics. *Business Week, Innovation* 1989. Pp. 1419.
- [17] *RS-232 Handbook*. (1988). Boulder, CO: Scientech, Inc.
- [18] Schonberger, Richard. (1986). *World Class Manufacturing*. NY: The Free Press.

AUTHOR'S PROFILE



Dr. Rafie Hamidpour

has completed his PhD at the age of 31 years from Atlanta and MCU and DE from KWU. He is the President and director of Pars Biomedical Research Center at Leawood, Kansas. He has published ten (10) Books, seven (7) patents and more than 38 papers in reputed journals and has been serving as an editorial board member of reviewer for *Journal of Traditional and complementary Medicine*.