

Design of Broadband W-slotted Microstrip Patch Antenna

Naresh Kumar Joshi, Prof. Anoop Singh Poonia, Ms. Manisha Uttamrao Birare, Ms. Sonal T. Patil

Abstract — In this paper we presented to improve the bandwidth a W-slot technique is used, it is efficient to enhance the bandwidth of antenna. A broadband W-slot microstrip patch antenna is designed which attains a bandwidth of 22.74% at 10dB return loss with centre frequency of 4.5GHz and also it attains maximum directivity 8.78dBi. It is designed by cutting a W-slot into the patch of antenna, because of this resonant slot, the antenna gives broad bandwidth. A coaxial feeding technique is applied to microstrip patch antenna for impedance matching. This antenna is best suitable for C-band frequency spectrum. The proposed antenna is designed and simulated using IE3D software.

Keywords — Broadband, Microstrip Antenna, Radiation Pattern, W-slotted Patch.

I. INTRODUCTION

Microstrip patch antennas are a well suited for wireless communication and satellite communication systems due to their attractive features of small size, low cost and weight, conformability, and ease of manufacturing, so these antennas have been developed in the last decades increasingly [1]-[2]. In many applications, the main issue of microstrip patch antennas is their narrow bandwidth. In recent years, many efforts have been dedicated to the bandwidth improvement of microstrip patch antennas. Many techniques have been employed for achieving broadband bandwidth [3]-[6].

In this paper we introduced W-shape patch which has been presented the good bandwidth improvement. The rectangular MSA has been realized by cutting either a W-slot yields broader bandwidth. W-slotted patch antenna is optimized for simplicity in design and feeding is proposed. The slot introduces a resonant mode whose frequency can be controlled with respect to the patch resonance frequency by tuning the slot dimensions, and the broader bandwidth is obtained [7]. The W-shape antenna is consist of rectangular patch with coaxial probe feeding is shown in fig.1. W- slot introduces the capacitive component in the input impedance to counteract the inductive component of the probe. Also to compensate the increasing inductive effect due to the slots, thickness of the substrate is increased; therefore as thickness increases the bandwidth increases accordingly [7]-[9]. Parameters of the antenna such as return loss, VSWR and radiation pattern are discussed in this paper. The method of moments is used for analysis. The proposed configuration was optimized using the IE3D software.

II. W-SLOT PATCH ANTENNA

The geometry of W-slotted patch antenna along with dimensions is depicted in fig.1. The antenna has a single patch of length L, width W and infinite ground plane separated by substrate of two dielectric materials. First layer is consisting of foam of height 3.4mm with relative permittivity of 1.07. Second layer is consisting of FR4 of height 1.6mm with relative permittivity of 4.4. The radiating patch is fed by a coaxial probe at a position (-12, 10) for proper excitation of the antenna over a broad bandwidth. We also checked feeding at a position (12, 10), then we found same result at both feeding point, this is because of W-slot is symmetrical to center of patch. Centre frequency chosen for this design is 4.5GHz. First we designed a rectangular microstrip patch antenna than cut W-slot the inside the patch. The detailed parameters are presented in Table I. Microstrip antennas without W-slot has large inductive reactance in the input impedance of patch, due to thick substrate

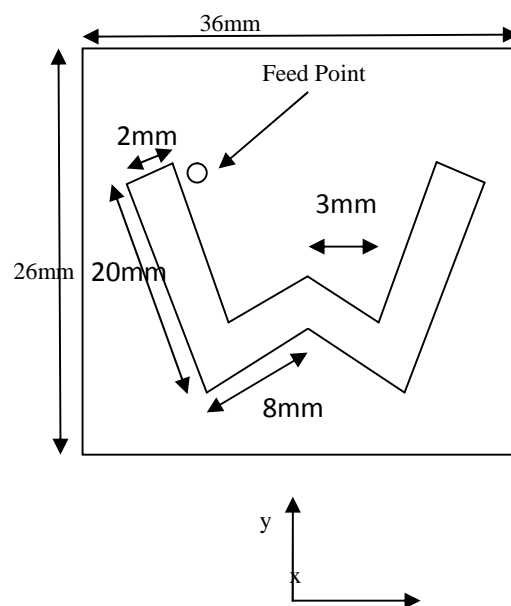

Fig.1. Geometry of Antenna

So W-slot introduces a capacitive component in the input impedance that compensates for the inductive component of the coaxial probe.

III. DESIGN METHODOLOGY

Designing of microstrip patch antenna depends on basically three parameters namely dielectric constant of substrate, height of the substrate and resonant frequency.

In this paper, we have chosen center frequency as 4.5GHz, dielectric constant as 1.07 and height of the dielectric substrate is 5mm.

Coaxial Feed position (X _f , Y _f)	(-12,10) or (12,10)
Substrate height (h)	5mm

A. Calculation of the width (W)

The width of the Microstrip patch antenna is given by as in [7],

$$W = \frac{c}{2f\sqrt{\frac{\epsilon_r+1}{2}}} \quad (1)$$

The width of proposed patch antenna was calculated by using (1) is W=32.765 mm, where c is the speed of light.

B. Calculation of Effective dielectric constant (ε_{reff})

The effective dielectric constant is given by as in [7],

$$\epsilon_{reff} = \frac{\epsilon_r+1}{2} + \frac{\epsilon_r-1}{2} \left[1 + 12 \frac{h}{W} \right]^{-1/2} \quad (2)$$

The effective dielectric constant was calculated by using (2) is ε_{reff} = 1.056.

C. Calculation of the Length Extension (L)

The extended length of the patch is given by as in [7],

$$L = 0.412h \frac{(\epsilon_{reff}+0.3)\left(\frac{W}{h}+0.264\right)}{(\epsilon_{reff}-0.258)\left(\frac{W}{h}+0.8\right)} \quad (3)$$

The extended length of patch was calculated by using (3) is L = 3.245mm

D. Calculation of the Effective length (L_{eff})

The effective length of patch is given by as in [7],

$$L_{eff} = \frac{c}{2f\sqrt{\epsilon_{reff}}} \quad (4)$$

The effective length of patch was calculated by using (4) is L_{eff} = 32.437mm

E. Calculation of the resonant length of patch (L)

The actual length of the patch is given by [7]

$$L = L_{eff} - 2L \quad (5)$$

This comes out to be 25.947mm.

Finally we have selected optimize dimension for patch i.e. 36mm × 26mm. A designed W-slotted patch is shown in fig. 2.

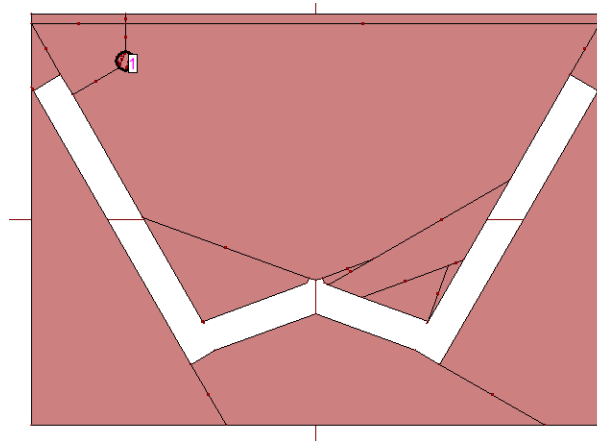

Fig. 2. Designed W-shape Patch

IV. RESULT & DISCUSSION

The bandwidth is a range of frequencies over which return loss is less than -10dB. We have observed simulated result of S₁₁ scattering parameter (return loss) of single element microstrip W-slotted patch antenna as is shown in Fig.3 and minimum return loss is -31.27dB. The measured bandwidth of the antenna is 1025 MHz, which is over 22.74% for S₁₁ 10 dB at resonant frequency of 4.5GHz. The VSWR plot for coaxial feed antenna is shown in Fig.4. VSWR is lie in the range of 1-2 which has been achieved for the frequency 4.5GHz, which is exactly at the center frequency value. The value for VSWR is 1:1.056. The Smith Chart plot represents that how the antenna impedance varies with frequency. The value of impedance should lie near 50 ohms in order to perfectly match the port with the antenna. As shown in fig.5 the impedance matching for this antenna is at 50.076 . A broadside radiation pattern is shown in fig.6 and directivity of antenna is 8.78dBi. This simulation analysis is done by using IE3D software version 14.

Table I: Dimension of W-slotted patch antenna

Frequency	4.5 GHz
Length of patch (L)	36mm
Width of patch (W)	26mm
Length of slot (L ₁)	20mm
Length of slot(L ₂)	8mm
Width of slot (W ₁)	2mm
Width of slot (W ₂)	2mm

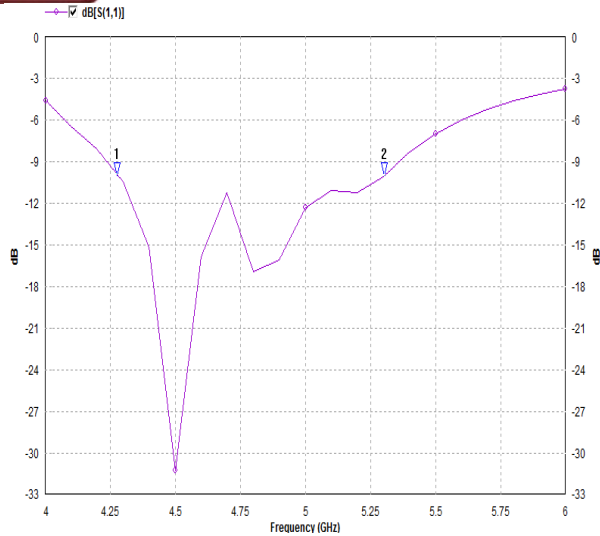

Fig. 3. Return loss of W-shape Patch Antenna

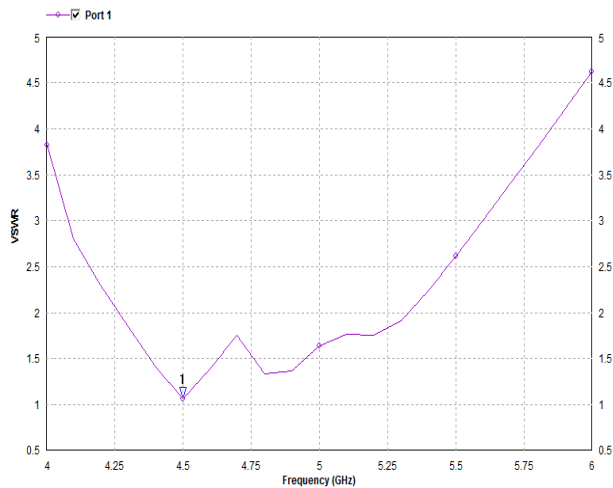

Fig. 4. VSWR of W-slot Patch Antenna

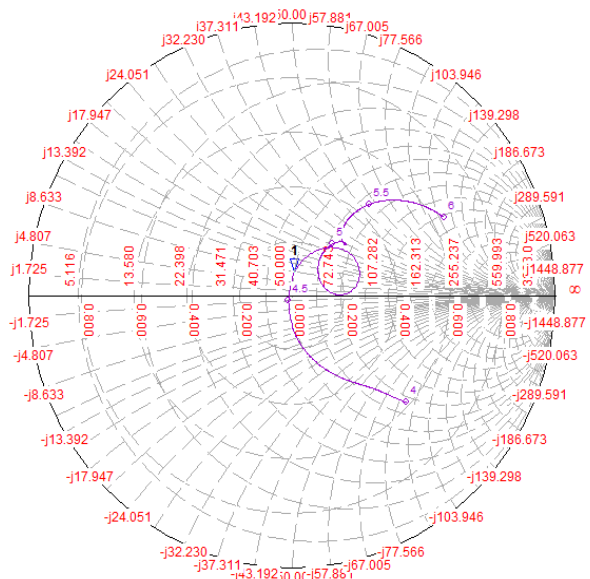

Fig.5. Smith Chart of W-slot Patch Antenna

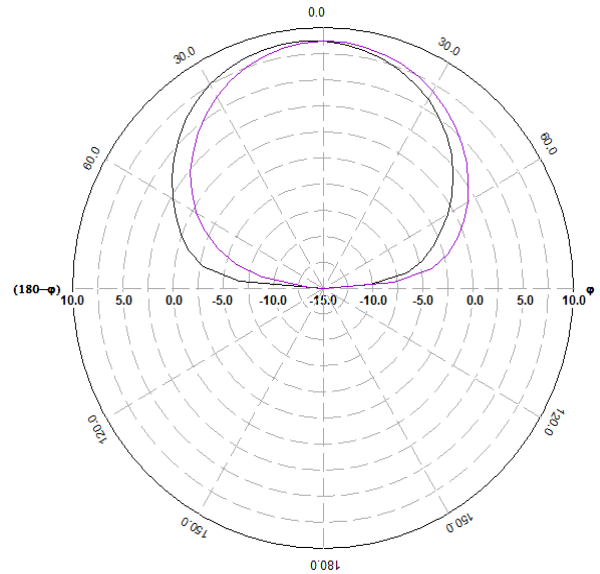

Fig.6. Radiation Pattern

V. CONCLUSION

The results indicates that the microstrip antenna have good broadband performance in return loss, VSWR and radiation pattern. The main concern is to study the bandwidth improvement of the microstrip patch antenna, it has been obtained by using W-slot symmetrically to one of the axis of patch. Broadband W-slotted microstrip antenna is designed and simulated using IE3D software version 14, which use method of moments. Thus the enhanced bandwidth of W-slotted microstrip patch antenna is obtained as 22.74% at probe feed position (-12,10) or (12,10), both feed point gives the same result at center frequency of 4.5GHz and maximum directivity is 8.78dBi. It also shows good impedance matching and broadside radiation pattern. This antenna is well suit for C-band frequency spectrum in communication area.

REFERENCES

- [1] D. R. Jahagirdar and R. D. Stewart "Non-leaky conductor backed coplanar waves guided fed rectangular microstrip patch antenna" *IEEE Microwave and guided letters*, 3 March 1998, pp.115-117.
- [2] N. Herscovici "New considerations in the design of microstrip antenna" *IEEE Transactions on Antennas and Propagation*, AP-46, pp.807-812, 6 June 1998.
- [3] D. Sanchez-Hernandez and I.D. Robertson "A survey of broadband microstrip patch antenna" *Microwave journal*, September 1996, pp.60-84.
- [4] Neeraj Rao "Gain and bandwidth enhancement of a microstrip antenna using partial substrate removal in multiple layer dielectric substrates" *PIER proceedings*, Suzhou, China, Sept.12-16, 2011.
- [5] T. Huynh and K. F. Lee, "Single layer single patch wideband microstrip antenna," *Electron. Letter*, vol. 31, no. 16, Aug. 1995, pp. 1310-1312.
- [6] A. Deshmukh and G. Kumar, "Compact broadband slotted rectangular microstrip antennas," *IEEE Antennas and Wireless Propagation letters*, vol. 8, 2009, pp.1410-1413.
- [7] G. Kumar and K. P. Ray, *Broadband Microstrip Antennas*" Dedham, MA: Artech House, 2003.

- [8] K. L. Wong, *Compact and Broadband Microstrip Antennas* New York: Wiley Inc., 2002.
- [9] C. A. Balanis, *Antenna Theory: Analysis and Design*, 2nd Edition" New York, John Wiley & Sons, 1997.
- [10] IE3D 14.0. Zeland Software Inc., Fremont, CA

AUTHOR'S PROFILE



Naresh Kumar Joshi

is pursuing M.Tech from RTU Kota with specializations in Digital Communication Systems. He received B.E. from NMU Jalgaon (MS). He has published five research papers in International Journals. He has presented six papers in National Conferences. He attended five National Workshops.

He has written two books. He has six years of teaching experience. His area of interest is Microstrip Patch Antenna, Digital Signal Processing and Microprocessor.

Email : nareshjoshi25@yahoo.com



Prof. Anoop Singh Poonia

is doing Ph.D. He has received M.Tech. & B.Tech. from Engineering College Kota, with specialization in Digital Communication Systems. He has membership of MIEEE, LMISTE, MIETE & MBES. Presently he is working as Director of Chandrawati

Education Society Jaipur. He has 18 years of teaching experience. He has published several research papers in International & National Journals. Also he has written several international & national books. His area of interest is Information Theory & Coding and Microwave Engineering.

Email: anoopsingh_25@rediffmail.com



Ms. Manisha Uttamrao Birare

is pursuing M.E. from NMU Jalgaon. She received B.E. from NMU Jalgaon (MS). Also she has obtained diploma from SSJ Polytechnic Jalgaon. She has presented papers in National Conferences. She has four years of teaching experience. Her area of interest is Electronic Devices & Circuit.

Email : sujyot.manisha@gmail.com



Ms. Sonal T. Patil

is pursuing M.E. from RGPV Bhopal. She received B.E. from KJ Somaiya, University of Mumbai (MS). She has four years of teaching experience. She has presented papers in National Conferences. Her area of interest is Electronic Devices & Circuit & Mobile Communication.

Email : st_patil14@yahoo.co.in