

# Optical Transmission System Using Free Space Optic (FSO)

M.A.Othman, M.M.Ismail, H.A.Sulaiman, M.H,Misran, M.A.M.Said

**Abstract** — A Free Space Optical (FSO) Transmission System is presented. The demand for high speed and high bandwidth communications channel is increasing in the new era of information age. FSO is presented as a solution for next generation high-speed wireless communication technology as it is free to implement, easy to install, secure and very high bandwidth. The simulation tool is important in the design as it allows researchers in optimization studies as well as reducing the design-to-development cycle. Opti-System Software is used in this project to complete the simulation of FSO transmission system. This design model assumes the weak turbulence approximation and the signal fading is based on log-normal statistics. Experimental results explain the performance of the completed system and offer methods of maximizing efficiency of such FSO-based communication systems. Discussion for the results of the simulation is done.

**Keywords** — Optical fibers, capabilities, FTTH, OCDMA.

## I. INTRODUCTION

Free Space Optics (FSO) is originally developed by the military of NASA.[4] FSO has been used for more than 3 decades in various applications in order to supply high speed communication links in remote locations. FSO communication link is still considered as a relatively new technology though fiber-optic communication has been widely used in worldwide telecommunications industry. FSO technology facilitates the bandwidth transmission capabilities that are likely to fiber optics where it uses optical transmitters and receivers and even enabling WDM-like technologies to operate through free space.[4]

FSO offers highly directional, high bandwidth communication channels. The FSO links can provide fiber-like data rates over short distances with low probability of interference [1]. Besides, it also present the last mile solutions in nowadays static communication system by substituting wired or microwave system [2-3].

FSO is an unexpectedly simple technology. The system is based on the connectivity between FSO-based optical wireless units where each of them consists of an optical transceiver together with transmitter and receiver to provide a full-duplex (bi-directional) ability.[4] Optical source with a lens that transmit light through the atmosphere to another lens receiving information are used in each of the optical wireless unit.[4] The receiving lens is connected to a high-sensitivity receiver through optical fiber at that specific point.[4] There are a number of advantages using FSO technology approach where it required no RF spectrum licensing and easily upgradeable.[4]

## II. SYSTEM MODELLING

Multiple transmitter and receiver system is modelled to analyze the performance for FSO link by using the OptiSystem Version 7.0 by Optiwave. The layout model for 4TX combination is shown in figure 1 below. The fundamental elements that form a FSO system are the FSO transmitter, a FSO channel and also the FSP receiver. The wavelength of the TX is set to be at 1550nm with transmitting power of 10dBm. To generate multiple laser beams, the output of the TX is duplicated using a fork, where the fork produce a multiple laser beams from one source that has the same value with the output signal from the TX.

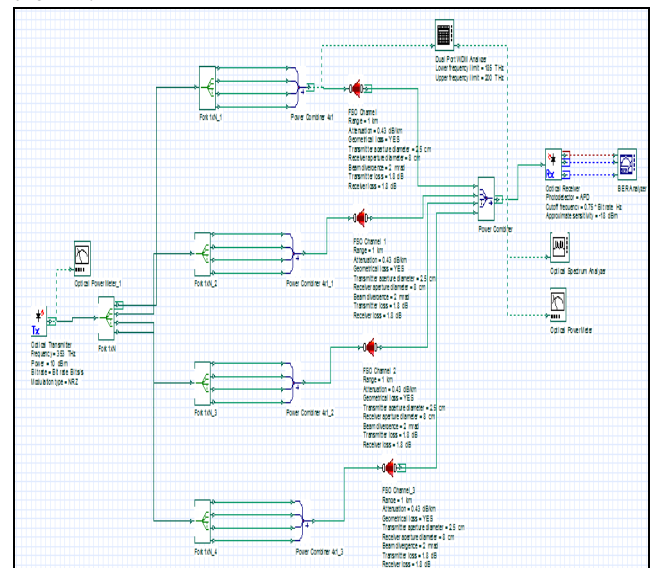

Fig. 1. FSO Circuit Diagram

The free space channel consists of two telescopes with the FSO channel between them. The apertures for the TX are taken at 2.5cm and RX is 8cm respectively. And the distance between TX/RX is set to 1 km with beam divergence of 2 mrad. The theoretical model used for single TX and single RX FSO system is as in equation (1). Modification of the system needed to carry out to enable the simulation of the multiple TX/RX.

$$P_R = P_T \times \frac{d_R^2}{(d_T + \theta_R)^2} \times 10^{\frac{\alpha R}{10}} \quad (1)$$

Where

$P_R$ : received power (dBm) at the receiver

$P_T$ : transmitted power (dBm)

$d_R$ : Receiver aperture diameter (m)

$d_T$ : Transmitter aperture diameter (m)

$\theta_R$ : Beam divergence (mrad)

R: optical link length h (km)

$\alpha$ : Atmospheric attenuation (dB/km).

What things must bear in mind when dealing with communication system are the losses. This may cause by equipment inefficiency and many other factors. Since there are two FSO terminals, each terminal will have a loss of 1.8dB, to be total up to 3.6dB for both FSO terminals. According to Beers-Lambert Law, the atmospheric losses for all laser power is as equation below.

$$L_{ATM} = e^{-\sigma \ell} \quad (2)$$

It is an exponential equation where,

(km): transmittance range of the laser

$\sigma$ : Typical attenuation coefficients (0.1 for clear air).

The attenuation is set to 0.43dB/km as the simulation is assumed to be clear weather condition. The entire multiple signals from the FSO channel will once again combined by using the power combiner before it is received by the RX. The sensitivity for RX is set to -45dBm. There are two visualizer tools used in the simulation. The first tools are two power meter which one of them used to measure the transmit power signal of TX output and another one used to calculate the average received power at the RX respectively. The another visualize tools is the BER analyzer which use to calculate the BER value and display the eye diagram for the FSO system. Finally, the bit rate used in the setup is set to be at 1 Gbps.

### III. RESULTS AND DISCUSSIONS

The analysis considers the various combinations of TX and RX. By varying the combinations of TX and RX, the multiple laser beams system can be measured and analyzed for its performances in terms of received power and the BER analysis using fixed parameter values of FSO channel, optical TX and optical RX. The analysis with the effect of FSO channel range also is conducted in order to see the FSO performance.

First, to see the effect of FSO channel range, the parameter of FSO channel range is varied by 1km, from 1km to 5km. The results of BER analysis are shown in figure below;

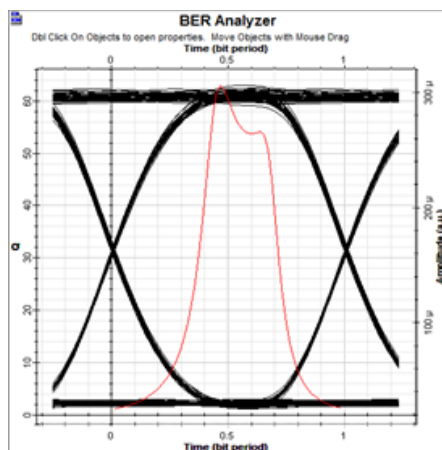

(a) 1km

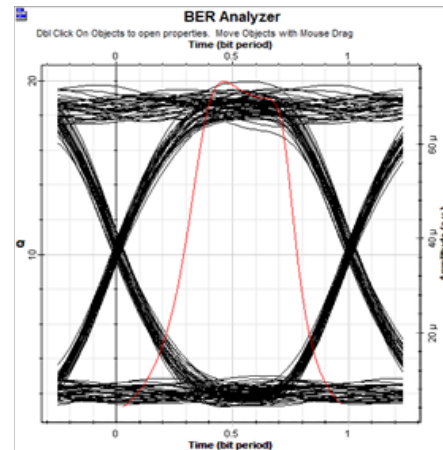

(b) 2km

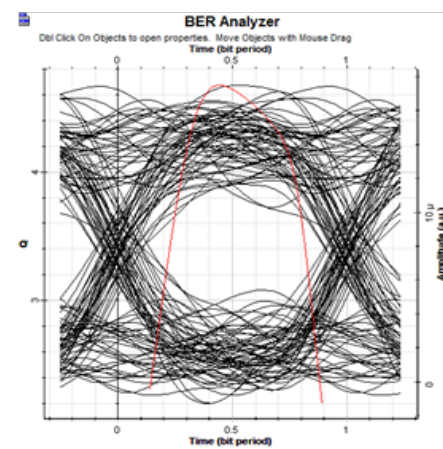

(c) 4km

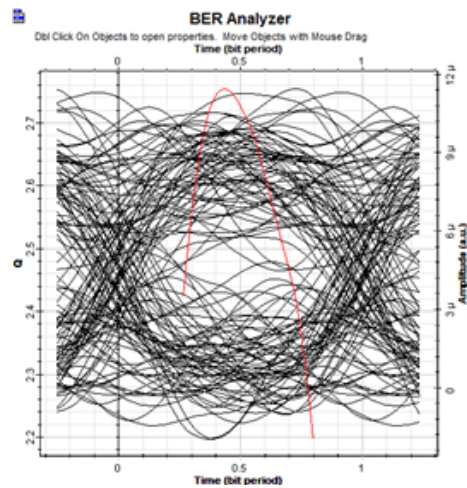

(d) 5km

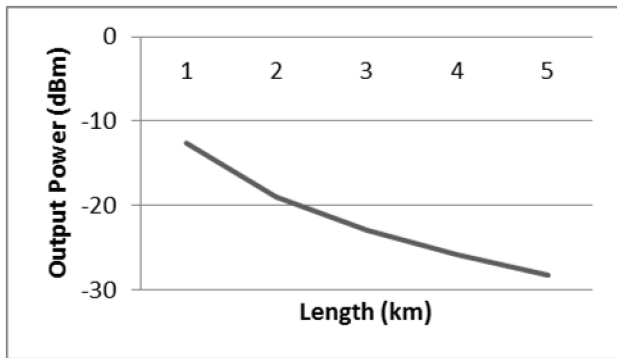

Fig.2. Graph of Output Power vs Length

Next, the performance of FSO is characterized by varying the combinations of TX, with Pin = 25dBm.

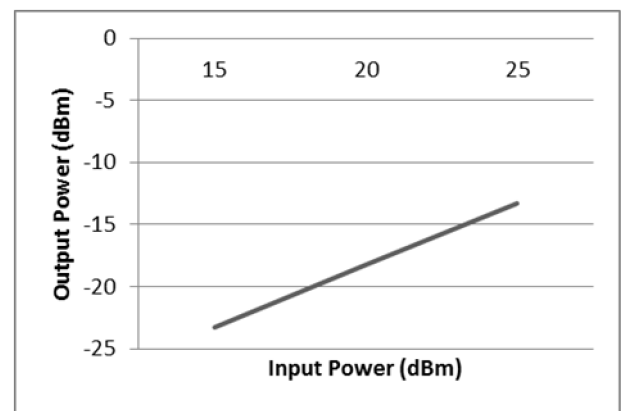
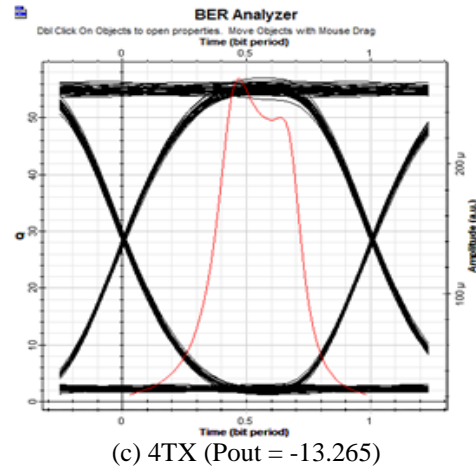
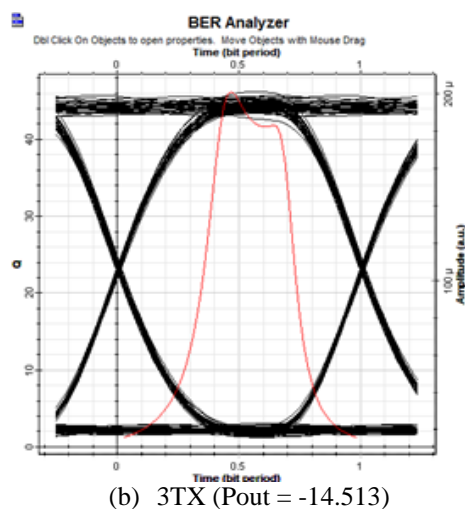
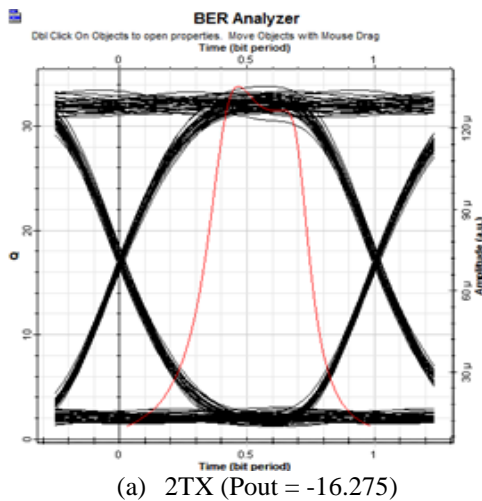

Fig.3. Output Power vs Input Power

From the experimental analysis, increasing the length of FSO channel will decrease the output power. This is because of the presence of the atmospheric effect where it causes the rapid fluctuation of received power and eventually will reduce the system quality. The BER results show that when increasing the length of FSO channel will increase the signal degradation as shown in the table the eye diagram of BER become more distortion. In order to get better quality of the signal, increasing the input power is a good option.

The display of the eye diagram can be analyzed to evaluate and measure system performances. Table above shows the eye diagram of the 2TX/2RX, 3TX/3RX, and 4TX/4RX combination. Increasing of number of TX and RX will produce fewer jitters of the signal and increasing the size of the eye opening. The significance of a wider eye opening is it will reduce the potential occurrence for data errors, the wider eye opening, the better the system performance. The output power also becomes better with less power loss.

#### IV. CONCLUSION

In conclusion, we have design an FSO link and optimization studies on FSO link for different setting parameter such as distance, power at transmitter, and multiplication of TX/RX. The characteristic of the FSO

system and the environment where the link is to be deployed will affect the planning of the link. As long as the FSO systems are used within their capabilities, the links will perform to the user satisfaction.

### ACKNOWLEDGMENT

Authors would like to thank Universiti Teknikal Malaysia Melaka for supporting this project and also for financing this journal.

### REFERENCES

- [1] L. Brandon, D Wilkerson, Dirk Giggenbach, and Bernhard Epple, "Concepts for fast acquisition in optical communications systems" Proceedings of the SPIE Free-Space Laser Communications VI, pp.108-1-9, 2006.
- [2] D.L. Begley, "Free-space laser communications: a historical perspective", The 15th Annual Meeting of the IEEE Lasers and Electro-Optics Society (LEOS) 2002, 3, pp.391-392, 2002.
- [3] Jayasri Akella, Murat Yuksel, Shiv Kalyanaraman, "Multi channel Communication in Free-Space Optical Networks for the Last-mile" 15th IEEE Workshop on Local & Metropolitan Area Networks (LANMAN) 2007, pp.43-48, 2007.
- [4] G. Hansel, E. Kube, J. Becker, J. Haase, P. Schwarz, "Simulation in the design process of free space optical transmission systems," Proc. 6th Workshop, Optics in Computing Technology, 2001.

### AUTHOR'S PROFILE

#### **Mohd Azlishah Othman**

was born on 21<sup>st</sup> October 1980 at Johor Bahru, Johor, Malaysia. He received Degree Bachelor of Engineering in Electrical Engineering (Telecommunication) from Universiti Teknologi Malaysia (UTM) on 2003. In September 2005 he joined Universiti Teknikal Malaysia Melaka (UTeM) as a Lecturer at Fakulti Kej. Elektronik dan Kej. Komputer (FKEKK). He received his Master's Degree in Computer and Communication Engineering from University of Nottingham, UK on 2005 and continues his PhD in Electrical and Electronic Engineering in University of Nottingham, UK from 2006 till now. His PhD thesis on the field of Terahertz circuits and devices. Currently he is working on RF and Microwave circuits and devices.

#### **Mohd Muzafar Ismail**

was born on 5 August 1985, Raub, Pahang, Malaysia. He received his first degree Bachelor of Engineering (Electrical-Telecommunications) at Universiti Teknologi Malaysia (UTM) on 2008. He got his Master's Degree, Master of Engineering (Electronic and Telecommunications) at UTM, 2010. Previously he worked as an Electrical Engineer at Venture Technocom System Singapore before joining Universiti Teknikal Malaysia Melaka as a lecturer on 2010 at Fakulti Kej. Elektronik dan Kej. Komputer. His research currently focus on Electromagnetics, Acoustic Engineering, Optical communication, and Optimization.

#### **Hamzah Asyrani Sulaiman**

was born on 28 Januari 1985, Jitra, Kedah, Malaysia. He received his first degree Bachelor of Engineering (Computer) at Universiti Teknologi Malaysia (UTM) on 2008. He got his Master's Degree, Master of Science (Computer Science) at UTM, 2010. He joined Universiti Teknikal Malaysia Melaka as a lecturer on 2010 at Fakulti Kej. Elektronik dan Kej. Komputer. His research currently focus on Computer Graphics and Visualization/ Data Computation and Algorithm with Graphics Processing Unit (GPU).

#### **Mohamad Harris Misran**

was born on 29 February 1980, Kluang, Johor, Malaysia. He received his first Degree Bachelor of Engineering (Electronics) at University of Surrey, 2006. Then he continued his Master's Degree on Master of Engineering (Telecommunication) at University of Wollongong, 2008. Then he joined Universiti Teknikal Malaysia Melaka as a lecturer on

2008 at Fakulti Kej. Elektronik dan Kej. Komputer. Currently his research on RF and Microwave circuits and Antenna Propagation.

#### **Maizatul Alice Meor Said**

was born on 26 Oktober 1982, Taiping, Perak, Malaysia. She received Bachelor of Engineering (Electronics) at University of Surrey on 2006. She received her Master of Engineering (Telecommunication) at University of Wollongong, 2009 and she joined Universiti Teknikal Malaysia Melaka as a lecturer on 2009 at Fakulti Kej. Elektronik dan Kej. Komputer. Currently she is working on RF & Microwave and Antenna propagation.