

# Introduction a Multi-Objective Function in Distribution Networks for Optimal Placement and Sizing of Distributed Generation Units Using Imperialist Competitive Algorithm

**Seyed Roohollah Sajadi**

Department of Electrical Engineering, Bandar Abbas Branch,  
Islamic Azad University, Bandar Abbas, Iran  
email:Ro.sajjadi@Gmail.Com

**Sirous Mohammadi**

Department of Electrical Engineering, Yasoj Branch,  
Islamic Azad University, Yasoj,  
Iran

**Abstract:** In recent years, the role of distributed generation in power industry has been expanding and, in near future, this role will be exceedingly substantial and determining. In this paper, finding the optimal location and size of distributed generation resources is investigated. The reduction of distribution network losses, voltage profile improvement and reduction of energy purchasing from the network are considered as the optimization objective. Since the intended objectives are not of the same type, in this thesis, using fuzzy systems, the objectives under investigation including voltage profile improvement and network losses reduction are modeled so that they are comparable and the problem can be solved in the form of a Multi Criteria objective function. In order to solve the above mentioned problem, imperialist competitive algorithm is utilized. The proposed methods are implemented on the IEEE 69-bus test system. The obtained results indicate that the proposed algorithm has the ability to find the optimal location and size of distributed generation resources, leading to the reduction of losses and improvement of voltage profile in the network.

**Keywords:** Multi-Objective Function, Distribution Generation (DG), Imperialist Competitive Algorithm.

## I. INTRODUCTION

As social welfare become higher, the need to supply electrical energy with high quality and reliability is also more felt. Power industry has been growing, day to day, in response to this need. Of the three sectors of production, transmission and distribution in a power system, the highest share of losses is related to distribution networks; the reduction of losses results in releasing system capacity, especially at peak hours, and delays the need to invest for developing the system. Today, with the movement of power systems from traditional structures towards a competitive structure, it is expected that distributed generation resources will play an essential role in this industry [1].

The inappropriate determination of location and size of distributed generation resources in the network can cause the increase in losses and the reduction of network reliability and, as a result, the consumable electricity reach the subscriber with far less quality. To avoid this issue and increase reliability along with the reduction of distribution network losses, using evolutionary algorithms is proposed

for finding optimal location and size of distributed generation resources in distribution network [2].

In recent years, according to the advances of artificial intelligence algorithms in various fields of management, especially in unpredictable environments, it seems that applying such algorithms for managing resources and enhancing network reliability is inevitable. It is noteworthy that in these types of algorithms, due to the exploratory nature of the solutions, the time of solving complex and multivariate problems is considerably reduced [3].

In [4], the effect of the location of distributed generation resources are examined, by offering indices which represent the effect of these units on the reduction of losses and reduction of feeders load. In [2], genetic algorithm is used for finding the distributed generation size and location in line with the reduction of network losses, considering its effect on the rearrangement of the power system. [5] has utilized Adaptive Weight Particle Swarm Optimization (APSO) algorithm for solving the problem of optimal placement of distributed generation with the aim of minimizing the real power losses, considering voltage limitations. In [6], the Ant Colony optimization algorithm is applied to determine the distributed generation size and location with the aim of minimizing investment costs and operating costs.

A multi-objective method is provided to determine the quantitative and qualitative parameters, using Fuzzy Logic for obtaining the optimal location of distributed generation units in line with planning the distribution systems in [7]. In [8], cost-benefit analysis can be utilized for finding the optimal type, location and size of distributed generation unit. In [9], a model is presented for planning the distribution system development, considering distributed generation resources. In [10], an evolutionary multi-objective method is proposed to overcome the finding of optimal solution while the objectives are incompatible with each other. In [11], using metal melting algorithm, the optimal location and size of distributed generation resources in a microgrid is determined, considering network layout, electric charge and heat energy required per bus. In [12], a combined method is utilized based on genetic algorithm and Optimal Power Flow for finding a suitable location for distributed generation resources. In [13], the impact of considering load

as a static model on optimal placement and sizing of distributed generation resources is evaluated in the distribution system. In [14], the authors see the main objective as determining the optimal location of distributed generation resources. An analytical method is presented in [15], based on the exact loss formula. In [16], Wind Turbines are examined as one type of distributed generation resources and its placement and sizing in the distribution system are discussed for minimizing losses; whereas, in [17], placement and sizing of Gas Turbine is debated as another type of distributed generation resources.

In [18], an evolutionary method is used for determining optimal capacity of distributed generation resources from the viewpoint of the distribution company. In [19], Tabu Search Algorithm is proposed for the optimal placement and sizing of distributed generation resources. Whereas [20] suggests utilizing Particle Swarm Optimization Algorithm to this end, in [6], Ant Colony Algorithm method is utilized for finding the optimum solution to install distributed generation resources in the network. In [21], genetic algorithm is used along with the concept of decision-making theory, for finding optimal location and size of distributed generation resources. In [22], the authors describe the use of genetic algorithm in finding optimal location and size of distributed generation resources in the distribution network with household consumption.

Using genetic algorithm, reference [23] determines the location and size of distributed generation resource, considering various load conditions. Moreover, in [24], similar algorithm is utilized for finding optimum solution to the intended optimization problem. Due to the complexities of optimizing the problem of placement and sizing distributed generation resources, using combined methods is proposed for this purpose. In [25], a combination of the best features of genetic algorithm and Tabu search method is utilized. In [26], an improved optimization method is applied to find optimal location and size of distributed generation resources. In [27], a combination of optimal power flow and genetic algorithm is used for finding the optimum solution. In [28], for the first time, the impact of distributed generation resources on transmission system congestion is evaluated, using Fuzzy Logic. Afterwards, utilizing distributed generation with the aim of the reduction of density is considered. In [29-30], using in wind turbines for managing transmission system congestion during operation. In [29], a power system is considered which contains intense penetration of wind fields. In [31], real time monitoring is assessed in managing transmission system congestion. Reference [32] further investigates using distributed generation resources in order to reduce network density. Authors offer various solutions for placement and sizing these units in the network.

In section II, a short summary is given regarding imperialist competitive algorithm. In section III, the

proposed algorithm is provided and achieving optimum solution is described. Section IV evaluates the method of the formation of objective function. In section V, sample systems and results of simulation are presented and the obtained results are analyzed and evaluated. And in the last section, the solving of the problem is concluded.

## II. IMPERIALIST COMPETITIVE ALGORITHM

Imperialist competitive algorithm, as evident from its name, has been inspired by the competition among various countries including colonizers and colonized countries. Similar to other evolutionary algorithms, this algorithm also begins with a number of random initial populations each of which called a "country." Some of the best elements of the population (equivalent to elites in genetic algorithm) are selected as the imperialists. The rest of the population is considered as the colonized. The colonizers, depending on their power, drag the colonies to their side with a specific process, which will, subsequently, be explained. The total power of every empire depends on both constitutive sections, i.e. the imperial country (as the central core) and its colonies.

In mathematical language, this dependence, with the definition of imperial power, is modeled as the sum of the imperialist country's power, in addition to a percentage of the average of its colonies' power. With the formation of the early empires, imperial competitiveness between them begins. If an empire cannot act successfully in imperialist competitiveness and add to its power, it will be removed from imperialist competitive scene. Consequently, survival of an empire is dependent on its power in attracting the colonies of rival empires, and dominating them. As a result, during the imperialist rivalries, the power of larger empires gradually increases and weaker empires will be eliminated. Empires will be forced to expand their colonies in order to enhance their power. Pseudo code related to the proposed algorithm is demonstrated in figure 1. For further studies on imperialist algorithm, see references [32-33].

1. Select some random points on the function and form early empires
2. Move the colonies towards the imperial country (matching policy)
3. If colonies exist in an empire with less expenditures than the imperialist, switch the place of the colony and the imperialist with one another
4. Calculate the total expenses of the imperialist (considering the expenses of the imperialist and its colonies)
5. Choose a colony from among the weakest empires and present it to an empire with the most possibility of dominance
6. Eliminate the weak empires
7. If merely one empire has remained, stop and otherwise go to number 2

Figure 1: Network of imperialist competitive algorithm

### III. PROPOSED ALGORITHM

The conducted fundamental steps to achieve an appropriate plan for distribution network development are as follows:

- 1 – Performing power flow in the base network and comparing voltage volumes with the allowed ranges.
- 2 – Selection of buses which do not contain suitable conditions with respect to voltage drop as candidates for placing distributed generation resources. The voltage of these buses is lower than 95% of the base voltage.
- 3 – Separate evaluation of each of the objective functions for the formation of membership functions in each of the objective functions.
- 4 – Performing multi-objective optimization to obtain the final response.
- 5 – Placing distributed generation resources according to the obtained response and drawing voltage and flow charts and comparing them with the allowed ranges for testing the obtained results.

### IV. OBJECTIVE FUNCTION FORMATION

The first objective function is the problem of minimization plan of the total cost of purchasing power standard (PPS) and cost of total target loss ratio (TLR) during the next 5 years.

In this article, the correlation for the formation of the first objective function is provided in reference [31]. Based on this reference, the reduction of purchasing costs is demonstrated with the following equation:

$$PPS = \sum_{t=1}^{N_{year}} \sum_{k=1}^{N_{DG}} \sum_{m=1}^{N_C} \delta_m \times P_{kt}^{DR} \times MCP_t^m$$

And the cost of the total losses TLR is as follows:

$$TLR = \sum_{t=1}^{N_{year}} \sum_{m=1}^{N_C} (Loss_{m,t}^{ini} - Loss_{m,t}^{DG}) \times MCP_t^m$$

In these equations,  $MCP_t^m$  stands for Market Clearing Price (MCP), which is displayed as below:

$$MCP_t^m = MCP_1^m \times (1+IR)^{t-1}$$

The second objective function is related to the necessities of minimum and maximum voltage of buses and maximal passable flow is required. Its objective function is formed easily and for this reason, in this article, the equations are not presented.

### V. NUMERICAL RESULTS

To examine the efficiency of the proposed method in this article, the intended method is tested on the standard IEEE 69-bus distribution network [34-35].(Figure2)

In this study, it is simultaneously attempted to solve the problems of network voltage drop as much as possible and to reduce the system costs. This is done through installation of distributed generation resources with suitable sizes in suitable buses. The results of solving the problem of the considered distribution system development using the proposed algorithm are introduced in the following sections.

Here, according to the proposed algorithm, first the network buses with the problem of voltage drop are detected which include 57 to 65 buses. Subsequently, based on the objective functions, optimization is determined using the conducted imperialist algorithm and distributed generation resources. In table 1, the distributed generation resources obtained from solving that problem are demonstrated, in which each of the chosen buses is shown in each 5-year time period of planning along with the cost of this development plan. As presented in table 1, in this condition, the optimization program, in addition to the reduction of costs, can bring voltage deviation rates to zero, which is one of the objectives of optimization.

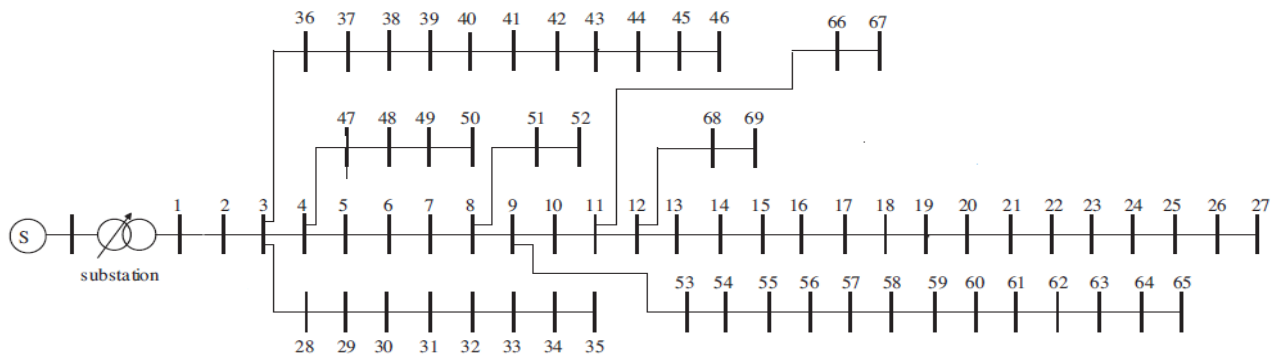

Figure 2: 69-Bus Network [34]

Table 1: installed distributed generation resources in various buses during planning years

	Year 1	Year 2	Year 3	Year 4	Year 5
Bus 57	0	0	0	0	0
Bus 58	0	0	0	0	0
Bus 59	0	0	0	0	0
Bus 60	0	0	0	0	0
Bus 61	0	0	0	0	0
Bus 62	900	0	0	0	600
Bus 63	600	0	0	0	0
Bus 64	0	900	600	0	0
Bus 65	0	0	0	0	0

cost of installation and operation of DG resources	1785361.5 dollars
Cost reduction	1921533.2 dollars
maximum voltage deviation	0 Volt

Figures 3 and 4, respectively, demonstrate voltages and network flows. As seen in these figures, by performing this plan during planning years, the problem of voltage drop is solved and, in addition, there is no problem in terms of excess flow.

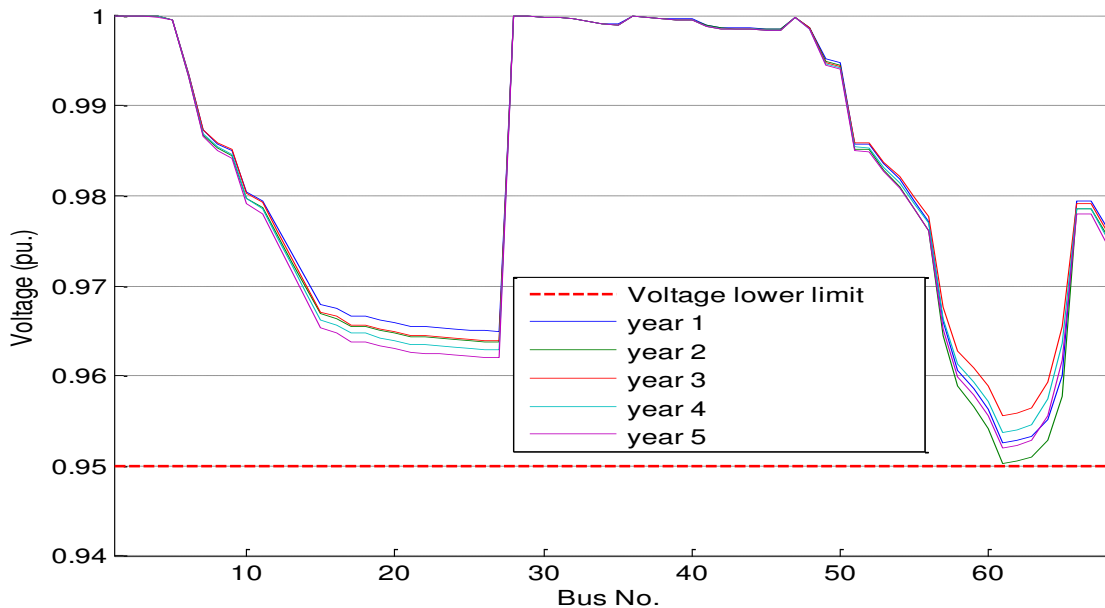

Figure 3: Voltage of various buses during 5 years of development

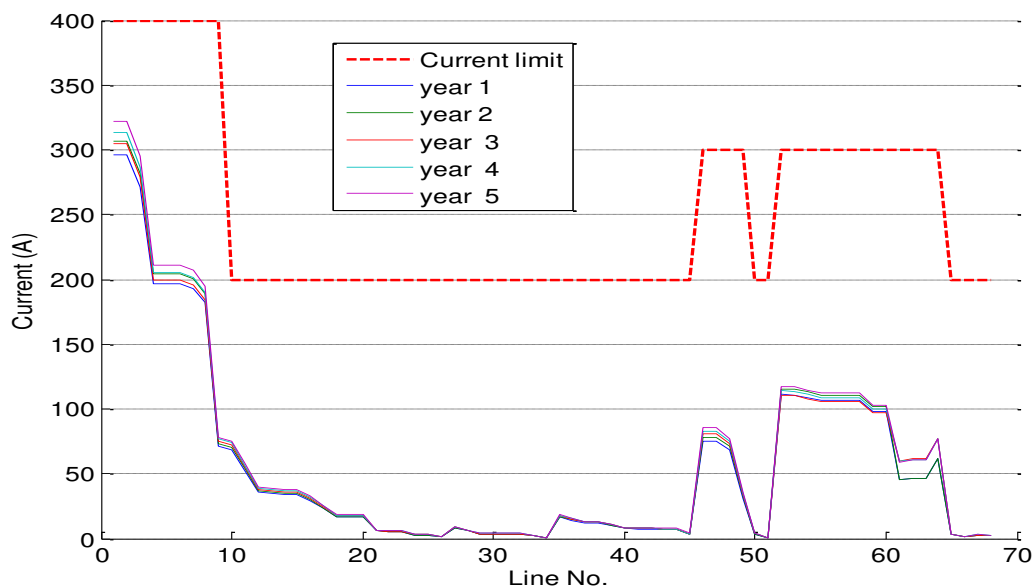

Figure 4: Flow of various lines during 5 years of development by installing suitable distributed generation resources

## VI. CONCLUSION

Finding the optimal size and location of distributed generation resources has been investigated in this thesis. The intended objective function includes voltage profile improvement, reduction of losses and reductions of power purchasing costs from the network related to the installation and use of distributed generation resources. The results of the simulations indicate that imperialist competitive evolutionary algorithm used for finding the optimal location and size of distributed generation resources can well solve the problem.

In this thesis, numerous studies have been conducted on the 69-bus standard network. The obtained results indicate that with the optimal placement and sizing of distributed generation resources, not only are the costs reduced, but the quality of electricity delivered to subscribers is improved as well. Voltage profile improvement leads to higher quality of electrical power system buses of subscribers.

## REFERENCES

- [1] Devender Singh, R. K. Misra, and Deependra Singh "Effect of load models in Distributed Generation planning," *IEEE Transaction on Power systems*, Vol. 22, no. 4, Nov. 2007..
- [2] Ann-Marie Borbely, Jan F. Kreider, "Distributed Generation, the Power Paradigm for the New Millennium", CRC Press, 2001.
- [3] Caisheng Wang "Modeling and Control of Hybrid Wind/Photovoltaic/Fuel Cell Distributed Generation Systems" Ph.D. Thesis Montana State University, 2006.
- [4] A. Algarni and K. Bhattacharya, "Novel sensitivity indices based siting of distributed generation resources," IEEE PES Annual General Meeting, pp 1-8, July, 2008.
- [5] W. Prommee and W. Ongsakul, "Optimal Multi-Distributed Generation Placement by Adaptive Weight Particle Swarm Optimization" Proc. of the IEEE International Conference on Control, Automation and Systems, pp 1663-1668, Oct. 2008.
- [6] H. Falaghi and M. Haghifam, "ACO Based Algorithm for Distributed Generation Sources Allocation and Sizing in Distribution Systems," Proc. of the IEEE Power Tech, pp 555-560, July, 2007.
- [7] A. Barin, L.N. Canha, M.R. Quadros, A. da Rosa Abaide, E. Maziero and G. Arend, "Analysis of the Impacts of Distributed Generation Sources considering the Appropriate Choice of Parameters in a Multi-objective Approach for Distribution System Planning," Proc. of the IEEE European Electricity Market Conference, pp. 1-6, May, 2008.
- [8] M. Ahmadigorji, A. Abbaspour T. F., A. Rajabi-Ghahnavieh, and M. Fotuhi-Firuzabad, "Optimal DG placement in distribution systems using cost/worth analysis," In Proceedings of World Academy of Science, Engineering and Technology, vol. 37, pp. 746-753, Jan. 2009.
- [9] Haffner, S. Pereira, L. F. A. Pereira, L. A. Barreto, L. S., "Multistage Model for Distribution Expansion Planning With Distributed Generation," IEEE transactions on Power Delivery, volume 23, issue 2
- [10] G. Celli, E. Ghiani, S. Mocci, F. Pilo, "A Multiobjective Evolutionary Algorithm for the sizing and siting of distributed generation," IEEE Transactions on Power Systems, volume 20, issue 2.
- [11] M. R Vallem, I. Mitra, "Siting and sizing of distributed generation for optimal microgrid architecture," Proceedings of the 37th Annual North American Power Symposium.
- [12] W. Liu, D. A. Cartes, G. K. Venayagamoorthy, "Particle Swarm Optimization base Defensive Islanding of Large Scale Power System", IEEE International Joint Conference on Neural Networks, 2006
- [13] T. Gozel, M. H. Hocaoglu, A. Baliki, "Optimal Placement and Sizing of Distributed Generation on Radial Feeder with Different Static Load Models", Proceedings of the International Conference on Future Power Systems, 2005
- [14] Caisheng Wang, M. Hashem Nehrir, "Analytical Approaches for Optimal Placement of Distributed Generation sources in Power Systems" IEEE Transactions On Power Systems, volume 19, issue 4.
- [15] N. Acharya, P. Mahat, N. Mithulananthan, "An Analytical Approach for DG Allocation in Primary Distribution Network," Electrical Power and Energy Systems, volume 28, issue 6.
- [16] Mahat, Pukar, Ongsakul, "Optimal placement of wind turbine DG in primary distribution systems for real loss reduction," Proceedings of the Energy for Sustainable Development Conference: Prospects and Issues for Asia, 2006.
- [17] Jurado.F, Cano.A, "Optimal placement of biomass fuelled gas turbines for reduced losses," International Conference on Energy Conversion and Management, 2006.
- [18] W. El-Khattam, K. Bhattacharya, YHegazy, M. M. A. Salama, "Optimal Investment Planning for Distributed Generation in a Competitive Electricity Market," IEEE Transactions on Power Systems, volume 19, issue 3
- [19] K. Nara, Y. Hayashi, K. Ikeda, T. Ahizawa, "Application of Tabu Search to Optimal Placement of Distributed Generators", Proceedings of the IEEE Power Engineering Society Winter Meeting, 2001
- [20] B. Sookanta, W. Kuanprab, S.Hanak, "Determination of the optimal location and sizing of distributed generation using particle swarm optimization," Proceedings of the ECTI International Conference, 2010
- [21] B.Kuri, M. A. Redfern, F. Li, "Optimization of Rating and Positioning of Dispersed Generation with Minimum Network Disruption," Proceedings of the IEEE TENCON, 2004
- [22] Haesen.E, M. Espinoza, B. Pluymers, I. Goethals, "Optimal placement and sizing of distributed generator units using genetic optimization algorithms," Electrical power quality utilization journal, volume 11.
- [23] SinghD, Devender Singh, K. S. Verma "GA based optimal sizing and placement of distributed generation for loss minimization," International Journal for Intelligent Systems and Technology, volume 2
- [24] C. L. T. Borges, D. M. Falcao, "Optimal Distributed Generation Allocation for Reliability, Losses, and Voltage Improvement," International Journal of Electrical Power & Energy Systems, volume 28, issue 6
- [25] M. Gandomkar, M. Vakilian, M. Ehsan, "A genetic based tabu search algorithm for optimal DG allocation in distribution networks," Journal of electrical power components and systems, volume 33
- [26] M. Gandomkar, M. Vakilian and M. Ehsan, "A Combination of Genetic Algorithm and Simulated Annealing for Optimal Distributed DG Allocation in Distributed Networks," Proceedings of the IEEE Electrical and Computer Engineering Canadian Conference, 2005
- [27] M. Mardaneh,G. B. Gharehpetian, "Siting and Sizing of DG Units Using GA and OPF Based Technique," IEEE Region 10 Conference, volume 3
- [28] Jianwei Liu, M. M. A. Salama, and Raafat R. Mansour, "Identify the Impact of Distributed Resources on Congestion Management", *IEEE Transaction on Power Delivery*, Vol. 20, N. 3, July 2005.
- [29] A. F. KaptueKamga, S. Völler, J. F. Verstege, "Congestion Management in Transmission Systems with Large Scale Integration of Wind Energy", *Integration of Wide-Scale Renewable Resources Into the Power Delivery System, CIGRE/IEEE PES Joint Symposium*, 2009.
- [30] A. Vergnol, J. Sprooten, B. Robyns, V. Rioux, J. Deuse, "Optimal network congestion management using wind farms" *Integration of Wide-Scale Renewable Resources Into the Power Delivery System, CIGRE/IEEE PES Joint Symposium*, 2009.
- [31] M. Afkousi-Paqaleh, A. Abbaspour Tehrani Fard, and M. Rashidi-Nejad, "Distributed generation placement for congestion management considering economic and financial issues" Electrical Engineering (Springer), Vol. 92, No. 6, pp. 193-201, 2010.
- [32] Esmaeil Atashpaz Gargari & Caro Lucas, "Imperialist Competitive Algorithm: An Algorithm for Optimization Inspired by Imperialistic



- Competition," 2007 IEEE Congress on Evolutionary Computation (CEC 2007) . pp 4661 – 4667.
- [33] Kargar, A.; Maleki, V., "Reconfiguration of distribution systems with distributed generators based on Imperialist Competitive Algorithm," Electrical Power Distribution Networks (EPDC), 2012 Proceedings of 17th Conference on , vol., no., pp.1,5, 2-3 May 2012.
- [34] J. S. Savier and Debapriya Das, "Impact of Network Reconfiguration on Loss Allocation of Radial Distribution Systems," IEEE Transactions On Power Delivery, Vol. 22, No. 4, October 2007.
- [35] Distribution Systems Determining the Optimal Configuration," Kashan Science Research Magazine, pp. 12-19, 2011.