

Comparative Cost Analysis for Sizing of Different Stand Alone and Hybrid Energy Systems

Emad Ahmed Sweelem

Electronics Research Institute National Research Center El-Tahrir St., Dokki, Cairo EGYPT
email:emadsweelem@yahoo.com

Abstract: Renewable energy stand-alone and hybrid energy system are promised the attractive solution to generate the electricity for rural and remote area. But, the only disadvantage to use it, it's energy cost (\$/kWh). In this paper, a formulation for optimizing the design of different kind of stand-alone and hybrid energy system are developed. This formulation employs linear programming techniques to minimize the average production cost of electricity while meeting the bad requirements in a reliable manner. The computer program (HOMER) developed reads the necessary input data, formulates the optimization problem by computing the coefficients of the objective function and the constraints and provides the optimum wind, solar, diesel, and battery ratings. In order to study the effect of parameters predefined by the designer on the optimum design, several sensitivity analysis studies are performed, and the effects of the expected energy not served, the bad level, the maximum available wind area, the maximum available solar areas, and the diesel engines' lifetime are investigated. Finally, the results show the comparison between the different kind of renewable energy systems with and without diesel. Also, the best system which gives us the minimum energy production cost and the maximum output energy.

Keywords: Cost Analysis, Hybrid Energy Systems, Stand-Alone System, Sizing, Analysis.

I. INTRODUCTION

Global environment concerns the ever increasing need for energy, coupled with a steady progress in renewable energy technologies are opened up new opportunities for utilization of renewable energy resources. In particular, advances in wind and PV generation technologies have increased their use in wind-alone, PV-alone, and hybrid wind/PV configurations. Moreover, the economic aspects of these renewable energy technologies are sufficiently promising at present to include the development of their market[1]-[3]. Several design scenarios have been proposed to design integrated renewable energy systems [4] where a combination of wind, solar, diesel, and in some cases other renewable resources have been used.

This software is capable of simulating the operation of systems that use various combinations of renewable energy sources taking into account the variability of the energy source, the capital cost, and the operating and maintenance costs of system components.

As can be concluded from the above, of the main concern in the design of an electric power system that utilizes renewable energy sources is the accurate selection of system components that can economically satisfy the bad demand.

In this paper, a cost comparison is given for the hybrid energy systems as well as for wind-alone and solar alone configurations. In this comparison, an economic analysis is performed for realizing the advantage of the hybrid energy system versus constructing stand-alone systems.

II. HYBRID SYSTEMS CONFIGURATION

A block diagram of the proposed integrated hybrid energy system is shown in Fig.1. This configuration can be used for the study of stand-alone system as well as network connected systems. For the network-connected configuration, the backup generator is not needed, and for the stand alone system, the switch connecting the AC bus to the generating unit is off. In this case, if the demand is greater than the sum of generation and storage, then power must be supplied by the backup generator. Furthermore, if the total generated power is greater than the demand and the storage is full, then the excess generation is dumped to an external voltage-controlled resistive load. The purpose of incorporating a dumped load into the system is to preserve the stability of the system frequency and voltage. If the excess energy cannot be dissipated usefully, then it must be disposed as heat by a controlled resistor. The peak power trackers will keep the wind and PV generators operating at their maximum power operating points.

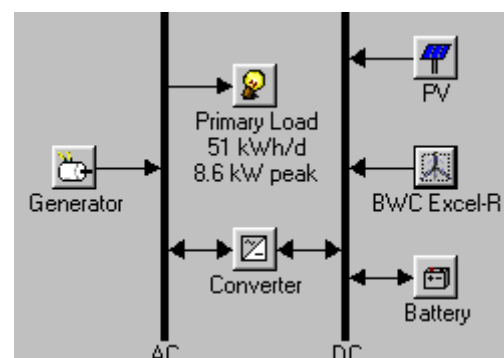

Fig.1: Hybrid energy system components.

III. MODELS OF SYSTEM COMPONENTS

Modeling is an essential step towards a good assessment of the hybrid system performance.

A. PV Panel

Usually, in photovoltaic systems, a maximum power point tracking system is used and therefore the PV modules often operate at maximum power. For this purpose, the estimation of maximum power becomes an

important parameter in modeling this system component. One of the most known models to describe the maximum output power of the PV module, in MPP conditions is given by [5]:

$$P_m = D_1 G + D_2 T_c + D_3 [\log G]^w + D_4 T_c [\log G]^w (1)$$

Where T_c is the junction temperature of PV cells, expressed in degrees Celsius ($^{\circ}\text{C}$) and G is the solar irradiance (W/m^2) incident on the modules. The coefficients D_{1-4} and w must be determined by fitting the model to experimental data measured in one or more test sites. T_c in Eq. 2 is habitually calculated using the NOCT (Normal Operating Cell Temperature [6]) given by the PV module manufacturer by:

$$T_c = T_a + [(NOCT - 20)/800]G (2)$$

NOCT is calculated for a wind speed $v = 1 \text{ ms}^{-1}$, an ambient temperature $T_a = 20 \text{ }^{\circ}\text{C}$ and an irradiance $G = 800 \text{ Wm}^{-2}$ [6].

B. Wind Turbine

Electric power output of wind turbine at a particular location depends on wind velocity at hub height and turbine speed characteristics. Wind velocity at hub height can be determined by using power-law equation [7]:

$$\frac{v(h)}{v(h_{ref})} = \left(\frac{h}{h_{ref}}\right)^{\alpha} (3)$$

Where $V(h)$ and $V(h_{ref})$ are the wind velocities at hub height (h) and reference height (h_{ref}), respectively and α is roughness factor. The α value fluctuates from less than 0.10 for very flat land, water or ice to more than 0.25 for heavily forested landscapes [7].

Fig. 2 illustrates typical power curve characteristics of wind turbine. Electric power output of a wind turbine

$P_w(V)$ can be expressed by the subsequent equations set [8].

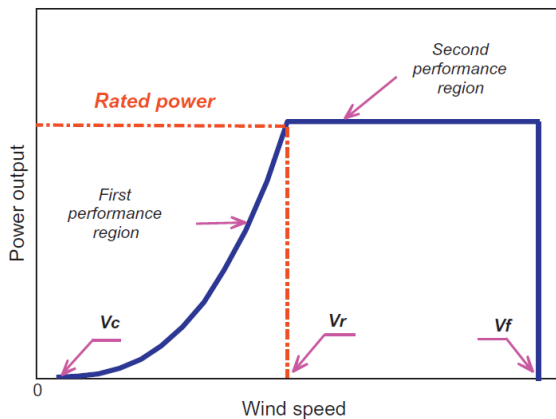

Fig. 2: Power curve characteristics of wind turbine.

$$P_w(v) = (av^3 - b)P_R, V_c \leq v \leq V_r (4)$$

$$= P_R, V_r \leq v \leq V_f$$

$$= 0 \text{ otherwise}$$

$$a = \frac{1}{(V_R^3 - V_C^3)} (5)$$

$$b = \frac{V_C^3}{(V_R^3 - V_C^3)} (6)$$

Usually, V_C is in the range of 2.5–3.5 m/s and V_F is in the range of 20–25 m/s.

C. Diesel Generator

The hourly fuel consumption of the diesel generator, $Q(t)$ (l/h) can be modeled by linear law based on output power required by the load [9]:

$$Q(t) = \alpha_{DG} P(t)_{DG, gen} + \beta_{DG} P_{DG, rat} (7)$$

Where α_{DG} (l/kW h) and β_{DG} (l/kW h) are coefficients of the consumption curve provided by the manufacturer while $P(t)_{DG, gen}$ (kW) and $P_{DG, rat}$ (kW) are power generated and rated power of the DG. The values allocated to α_{DG} and β_{DG} are 0.246 and 0.08145 l/kW h, respectively [9].

The DG efficiency (kW h/l) is expressed as [10]:

$$\mu_{DG} = \left[\frac{P(t)_{DG, gen}}{Q(t)} \right] = \left[\frac{1}{\left(\alpha_{DG} + \beta_{DG} \frac{P_{DG, rat}}{P_{DG, gen}} \right)} \right] (8)$$

The efficiency in percentage (%) of the lower heating value (LHV) of Gas-oil can be defined as follows:

$$\mu_{DG\%} = P(t)_{DG, gen} (\text{Kw}) * 100 / (Q(t) * (l/h) * LHV_{\text{Gasoil}} (\text{Kwh/l})) (9)$$

D. Battery Bank Modeling

According to the energy balance established between the production units and the load, the state of charge of battery can be calculated from the following expressions:

Charging process,

$$E_{\text{Bat}}(t) = E_{\text{Bat}}(t-1) * (1 - \sigma) + [E_{\text{Gen}}(t) - E_{\text{Req}}(t) * \mu_{\text{inv}}] * \mu_B (10)$$

Discharging process:

$$E_{\text{Bat}}(t) = E_{\text{Bat}}(t-1) * (1 - \sigma) - [E_{\text{Req}}(t) * \mu_{\text{inv}} - E_{\text{Gen}}(t)] (11)$$

Where $E_{\text{Bat}}(t)$ and $E_{\text{Bat}}(t-1)$ are the energy stored in battery bank (W h) at hour t and $t-1$, respectively; σ is hourly self-discharge rate; $E_{\text{Req}}(t)$ is the hourly energy required by the load; μ_{inv} and μ_B are the efficiency of inverter and charge efficiency of battery bank, respectively and $E_{\text{Gen}}(t)$ is the energy generated by the hybrid PV/wind system at hour t . $E_{\text{Gen}}(t)$ is given by:

$$E_{\text{Gen}}(t) = N_{\text{PV}} E_{\text{PV}}(t) + N_{\text{W}} E_{\text{W}}(t) (12)$$

Where $E_{\text{PV}}(t)$ and $E_{\text{W}}(t)$ are the hourly energy produced by one PV module and one wind turbine, respectively and N_{PV} and N_{W} are the number of PV modules and wind turbines, respectively.

At any time t , the charged quantity of the battery bank is subject to the following two constraints:

$$E_{\text{bat, min}} \leq E_{\text{bat}}(t) \leq E_{\text{bat, max}} (13)$$

The maximum energy stored in battery bank $E_{\text{Bat, max}}$ takes the value of nominal capacity of battery bank CB, and the minimum energy stored $E_{\text{Bat, min}}$, is determined by the maximum depth of discharge (DOD): $E_{\text{Bat, min}} = (1 - \text{DOD}) * \text{CB}$. According to the manufacturers' specifications, the battery's lifespan can be stretched to the maximum if DOD takes the value of 30–50%. In this paper, the DOD takes the value of 50%.

IV. CRITERIA FOR OPTIMAL SIZING SYSTEM

To select an optimal combination of a hybrid system to meet the load demand, assessment can be established on reliability basis and power supply economy. The recommended methodology for optimal components selection of the studied hybrid system is illustrated in the next sections.

A. Reliability Criteria

In this study, reliability of the system is expressed in

terms of Total Energy Deficit (TED) which is defined as the ratio of energy not supplied to the consumer when he was requested on the total energy required. TED can be expressed as follows:

$$TED = \frac{\sum_{t=1}^T (E_{Req}(t) - E_{Supp}(t))}{\sum_{t=1}^T E_{Req}(t)} \quad (14)$$

Where $E_{Req}(t)$ is the energy required by the consumer at hour t , $E_{Supp}(t)$ is the hourly energy actually supplied to the consumer given as follows and T is the system period analysis(1 year in this study).

$$E_{Supp}(t) = (E_{Bat}(t) + E_{Gen}(t-1) - E_{bat, min}) * \mu_{inv} \quad (15)$$

As the energy management strategy developed in this study does not allow any energy deficit, therefore, the allowed value of TED is 0%.

From the above-described situations, a program is illustrated in HOMER to size the components for each configuration, for zero load rejection.

B. Economic Criteria

In the literature, several economic criteria are used for economic analysis of decentralized renewable energy systems. These criteria include the life cycle cost, total annualized cost and levelized cost of energy [11]). In this section, economical approach based on the Total Net Present Cost (TNPC) and Energy Cost(EC) is developed for system configurations considering the life period and replacement costs of the individual subsystem.

1. Total Net Present Cost (TNPC)

The Total Net Present Cost (TNPC) is a key financial indicator for economic viability assessment of an investment project. According to the studied hybrid system, TNPC can be expressed as follows energy [11]:

$$TNPC(\$) = IC + PW_{C_{rec}} + PW_{C_{non-rec}} \quad (16)$$

Where IC is the initial cost of the system components(encompassing costs of civil work, installation and connections)and $PW_{C_{rec}}$ and $PW_{C_{non-rec}}$ are factors for the conversion of the recurring and non-recurring costs to their present worth. These two factors are respectively defined by [11]:

$$PW_{C_{rec}} = C_{rec} \frac{\left[\frac{1+e}{1+d} \right] \left\{ \left[\frac{1+e}{1+d} \right]^{\epsilon} - 1 \right\}}{\left[\frac{1+e}{1+d} \right] - 1} \quad (17)$$

$$PW_{C_{non-rec}} = C_{non-rec} \frac{\left[\frac{1+e}{1+d_{adj}} \right] \left\{ \left[\frac{1+e}{1+d_{adj}} \right]^{\epsilon} - 1 \right\}}{\left[\frac{1+e}{1+d_{adj}} \right] - 1} \quad (18)$$

Where C_{rec} and $C_{non-rec}$ are the recurring and non-recurring costs respectively, ϵ and e are the interest and escalation rates, respectively. n is the system life period in years(25 years) and d_{adj} is the adjusted interest rate given as follows, P is number of years between two successive payments for non-recurring costs.

$$d_{adj} = \frac{(1+d)^P}{(1+d)^{P-1}} - 1 \quad (19)$$

2. Energy Cost (EC)

The Energy Cost (EC) is developed to be one of the most excellent economic profitability indicators of system cost analysis in this study. EC is defined as the total cost of the whole hybrid system at the annual electrical energy produced by the system. It can be defined as [11]:

$$EC \left(\frac{\$}{kWh} \right) = \frac{TNPC * CRF}{\sum_{t=1}^{8760} E_{Gen}(t)} \quad (20)$$

Where CRF is the capital recovery factor which is given by:

$$CRF(d, \epsilon) = \frac{d(1+d)^{\epsilon}}{(1+d)^{\epsilon} - 1} \quad (21)$$

V. RESULTS

Renewable Energy Laboratory software HOMER (Hybrid Optimization Model for Electric Renewables) [1]is a general purpose hybrid system design software. It has the option to investigate a hybrid energy system consisting of components such as photovoltaic, wind turbines, micro hydro, biomass, battery storage and inverters. It was developed to address the need for a hybrid system design tool accurate enough to reliably predict system performance [Appendix (1)]. HOMER is an optimization model, which performs many hundreds or thousands of approximate simulations in order to design the optimal hybrid system. It is simple and efficient enough to conveniently evaluate a large number of design options in its search for the optimum. Homer has been used by a number of researchers to determine an optimum hybrid energy system. HOMER takes one-year of hourly community load, wind data and solar data as inputs (as shown in Figs 3,4,5) . Other inputs include component technical details and costs. Optimization parameters may be selected as required.

Figs 6&7 show the total net present cost and the levelized energy cost for the different hybrid energy systems. These figures indicate that, the highest cost system is associated with the Diesel generator, while the lowest cost system is PV-Diesel-Battery.

Figs 8&9 illustrate the total annual production and the corresponding total annual unserved energy for the different systems. Fig.8. indicate that the highest energy production is associated with the Diesel generator, while the lowest energy production is associated with the PV-Diesel-Battery hybrid system. At the same time, Fig.9.illustrates that the diesel generator can cover the load without unserved energy while the PV-Diesel-Battery has the lowest unserved energy of the remaining system.

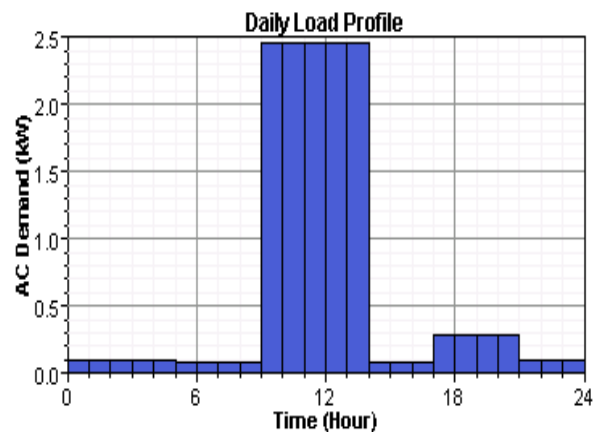

Fig.3: Load profile.

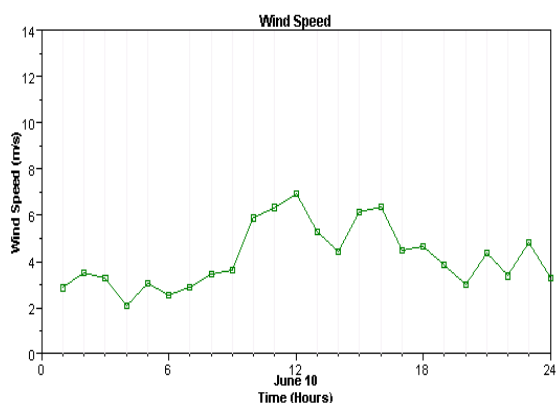

Fig.4: Wind speed monthly average.

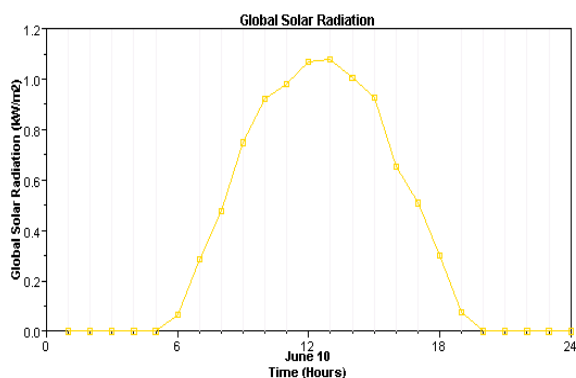

Fig.5: Monthly average solar insolation.

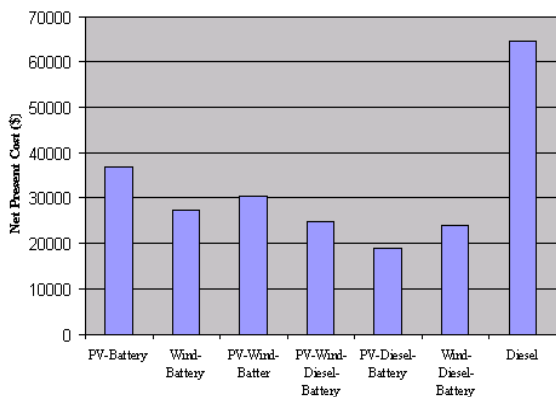

Fig.6: The net present cost for different hybrid energy systems.

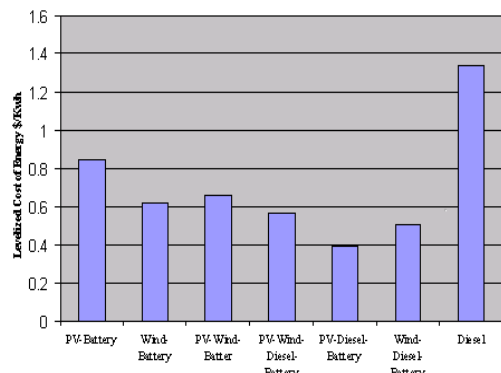

Fig.7: The levelized cost of energy (\$/kWh) for different hybrid energy systems.

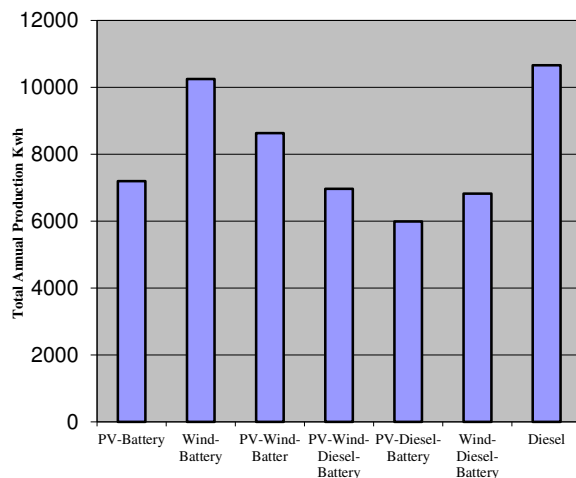

Fig.8: The total annual production (Kwh) for different hybrid energy systems.

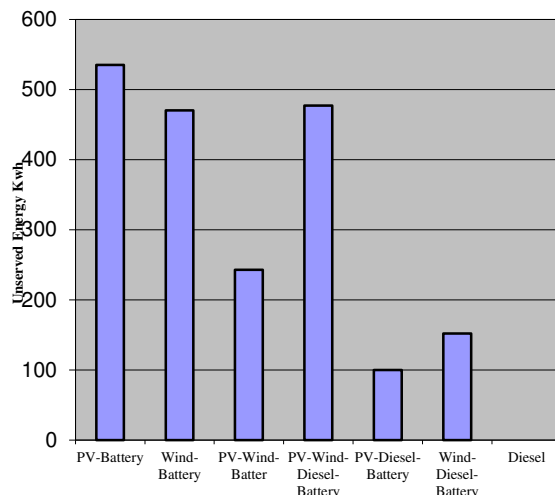

Fig.9: The unserved energy Kwh for different hybrid energy systems.

VI. CONCLUSION

In this paper, a formulation for optimizing the sizing of an autonomous PV-wind-diesel-battery hybrid energy system is developed. This formulation employs linear programming techniques to minimize the average production cost of electricity while meeting the load requirements in a reliable manner. The computer program reads the necessary data that formulates the optimization problem by computing the coefficients of the objective function, the constraints, and provide the optimum wind, solar, diesel and battery ratings. Where, a cost and energy comparison between the different suggested hybrid energy systems is carried out. Although, the Diesel generator can supply the load with the highest reliability, it has the highest cost of all the considered systems. At the same time the PV-Diesel-Battery system is the most economical system that can cover the load reliably.

REFERENCES

[1] Homer, Pro., Hybrid Optimization for Electric Renewable Program: NREL (National Renewable Energy Laboratory), USA; 2012.

[2] Musgrove, A., R., "The Optimization of Hybrid Energy Conversion Systems for Remote Area Power Supply", 5th International Conference on Energy Options, London. UK, 1987.

[3] Zambrano, T. And Lindberg, "Development of a Component Sizing Optimization Model for Wind Diesel System Design", 8th ASME Wind Energy Symposium, New York, 1989.

[4] R. Chedid and Y. Saliba, "Optimization and Control of Autonomous Renewable Energy Systems, International", Journal of Energy Research, 1996, Vol. 20, pp. 609-624.

[5] Rosell, J.I., Ibanez, M., "Modeling power output in photovoltaic modules for outdoor operating conditions", Energy Conversion Management, 2006, Vol. 47, pp. 2424-2430.

[6] Evans, D.L., "Simplified method for predicting photovoltaic array output", Solar Energy, 1981, Vol. 27, pp. 555-560.

[7] Hrayshat, E.S., "Techno-economic analysis of autonomous hybrid photovoltaic/diesel/battery system" Energy Sustainable Development, 2009, Vol. 13, pp. 143-150.

[8] Deshmukh, M.K., Deshmukh, S.S., "Modeling of hybrid renewable energy systems", Renewable Sustainable Energy, 2008, Rev. 12, pp. 235-249.

[9] Ismail, M.S., Moghavvemi, M., Mahlia, T.M.I., "Techno-economic analysis of an optimized photovoltaic and diesel generator hybrid power system for remote houses in a tropical climate", Energy Conversion Management, 2013, Vol.69, pp. 163-173.

[10] Dufo-Lo'pez, R., Bernal-Agusti'n, J.L., "Design and control strategies of PV/diesel systems using genetic algorithms", Solar Energy, 2005, Vol. 79 (1), pp. 33-46.

[11] A. Kaabeche, R. Ibtouen, "Techno-economic optimization of hybrid photovoltaic/wind/diesel/battery generation in a stand-alone power system", Solar Energy, 2014, Vol. 103, pp. 171-182.

Appendix (1)

Primary Load

Data Source: Generated from monthly profiles
 Rescale Average: 14.665 kWh/d

Global Solar

Data Source: Generated from monthly averages
 Rescale Average: 5.118 kWh/m²/d
 Latitude: 32 deg. 0 min. N

Wind Speed

Data Source: Generated from monthly averages
 Rescale Average: 3.000 m/s

PV Array Costs:

Rated Capacity (Kw)	Capital Cost (\$)	Replacement Cost (\$)	O&M Cost (\$/yr)
1.000	7000	6000	10

Derating Factor: 90 %
 Lifetime: 20 years

Generic kW Costs:

Number of Turbines	Capital Cost (\$)	Replacement Cost (\$)	O&M Cost (\$/yr)
1	5500	3000	80
2	10500	5700	120
3	14300	8300	160

Power Curve: Fig.2.
 Current Type: DC
 Lifetime: 15 yr
 Power Curve Scaling Factor: 1.00
 Wind Speed Scaling Factor: 1.10

Diesel Costs:

Rated Capacity (Kw)	Capital Cost (\$)	Replacement Cost (\$)	O&M Cost (\$/hr)
8.000	7000	6000	0.25

Operational Lifetime: 1500 hr.
 Min. Load Ratio: 30%
 Fuel Curve Intercept Coefficient: 0.080 L/hr/Kw
 Fuel Curve Slope: 0.250 L/hr/Kw
 Fuel Price: 0.20 \$/L

Battery Bank

Battery Type: Trojan L-16

Costs:

Nominal Capacity (Kw)	Capital Cost (\$)	Replacement Cost (\$)	O&M Cost (\$/yr)
1.000	100	90	5

Cycle Life: 550 full cycles
 Float Life: 10 yr.
 Max. Charge Rate: 1.00 A/Ah
 Nominal Capacity: 2.1 Kwh
 Max. Capacity: 2.74 Kwh
 Capacity Ratio: 0.4151
 Rate Constant: 0.2581
 Min. State of Charge: 40%
 Initial State of Charge: 100%
 Roundtrip Efficiency: 80%

Inverter Costs:

Rated Capacity (Kw)	Capital Cost (\$)	Replacement Cost (\$)	O&M Cost (\$/yr)
4.8	3500	3400	40

Lifetime: 10 yr
 Efficiency: 90%

Rectifier

Relative Capacity: 75%
 Efficiency : 85%.

AUTHORS PROFILE



E. A. Sweelem: I had born in Cairo on Aug. 1969. Feb. 2003 PhD in Electrical Engineering, Cairo University, Egypt

Thesis: A New Development for Modeling and Control of PV Hybrid Energy System. A Government Fellowship in Cottbus-Germany (Technical University of Cottbus), where the experimental part of my PhD were done there (from 18/11/2000 to 17/11/2002). Nov. 1997 M.Sc. in Electrical Engineering Cairo University, Egypt Thesis: A Modified Air Cooling for Photovoltaic System. A Scholarship from DAAD (German Authority) in Kassel-German (Solar Energy Institute ISET), Where experimental part of my M.Sc. were done there (from 1/11/1995 to 31/12/1996). July 1991 B.Sc. in Electrical Engineering Cairo University, Egypt Grade: very good with honors Graduation project grade: distinction.

I am working now in Electronics Research Institute, PV Department and my position is Researcher Since 2003 till now. I have published more than 14 papers in the field of solar cells and take shared in more than 5 research projects.