

Reducing Total Harmonic Content of 7-Level Inverter by Use of Cuckoo Algorithm

Mahmoud Enayati

Department of Electrical Engineering, Bandar Abbas Branch,
Islamic Azad University, Bandar Abbas, Iran
email: enayati.mahmoud@gmail.com

Sirous Mohammadi

Department of Electrical Engineering, Yasoj Branch, Islamic
Azad University, Yasoj, Iran

Abstract: In this paper, a novel procedure to find the firing angles of the multilevel inverters of supply voltage and, consequently, to decline the total harmonic distortion (THD), has been presented. In order to eliminate more harmonics in the multilevel inverters, its number of levels can be lessened or pulse width modulation waveform, in which more than one switching occur in each level, be used. Both cases complicate the non-algebraic equations and their solution cannot be performed by the conventional methods for the numerical solution of nonlinear equations such as Newton-Raphson method. In this paper, Cuckoo algorithm is used to compute the optimal firing angle of the pulse width modulation voltage waveform in the multilevel inverter. These angles should be calculated in such a way that the voltage amplitude of the fundamental frequency be generated while the total harmonic distortion of the output voltage be small. The simulation and theoretical results for the 7-level inverter offer the high applicability of the proposed algorithm to identify the suitable firing angles for declining the low order harmonics and generate a waveform whose total harmonic distortion is very small and it is almost a sinusoidal waveform.

Keywords: Evolutionary Algorithms, Multilevel Inverters, Total Harmonic Content

1. INTRODUCTION

As the power grids develop rapidly, issues such as energy conversion, new energies and smart grids, appear. Among all these issues, power electronic has been greatly important. Nowadays, power electronic instruments are produced in variety kinds and used in different applications. Considering these instruments, inverters are one of the most important and applicable ones. Inverters are machines which can convert direct current (DC) to the alternative current (AC).

Multilevel Inverters have many applications including, using in FACTS instruments [1], HVDC lines [2], and electrical drives [3]. Different topologies and structures are proposed for the multilevel inverters, three of which are proposed in this paper:

- 1- Clamped diode or clamped null
- 2- Clamped capacitor or hanged capacitor
- 3- Inverter with H-bridge inverter or separate DC supplies

Nevertheless, such inverters create harmonics which cause some problems such as reduction in the power quality. Therefore, in order to improve the inverter performance and boost the output quality, different methods have been proposed by the researchers which

include, using low-pass filters in the inverter output to remove high order harmonics, using multilevel structures method to decrease the total harmonic distortion (THD) and also using different switching strategies such as SHEPWM and OMTD [4].

Switching strategy aims to calculate the firing angles in such a way that, firstly, the voltage amplitude of the fundamental frequency be generated and secondly, excessive harmonics not be produced or the total harmonic distortion of the output voltage be small. One of the strategies used in the multilevel inverters is SHEPWM. In other words, in addition to the functionality of multilevel inverters to reduce the total harmonic content, by use of the SHEPWM strategy, some harmonics are selected and as much as possible closed to zero. Therefore, the main problem to control the multilevel inverters is to find the firing angles. This method is used to eliminate the low order harmonics, provided that the fundamental harmonics are satisfying.

In this method, by solving N equations, $N-1$ low order harmonics can be eliminated. Harmonic elimination is done for the harmonics whose order is more than four. These problems are nonlinear and their solution cannot be performed by the conventional methods for the numerical solution of nonlinear equations such as Newton-Raphson method [5].

For example in [6], solution of the nonlinear equations, regarding removal of the selective low order harmonics in a multilevel inverter by use of Newton-Raphson method, is presented.

Another method presented in [7], has mathematical base and makes it possible to solve the problem. Nevertheless, this method has many complications and is greatly time-consuming, moreover, when the input voltage alters, wide variety of changes should be employed in the method.

Furthermore, Homotopy algorithm is utilized to determine and solve equations [8]. In [9], one special method is used to remove selective harmonics to identify the switching angles in a multilevel inverter, and moreover, a microprocessor is utilized to calculate these angles online in different applications.

In [10], a new algorithm, namely, Memetic, is offered as a strong and applicable tool to remove the selective low order harmonics in a multilevel inverter.

In [11], it is attempted to combine topologies of different multilevel inverters and PWM technique, to reduce the output voltage harmonic. When the number of DC input supplies of an inverter increases, i.e. the number of levels boosts, the amount of output voltage wave steps

augments and consequently the output waveform resembles more to the sinusoidal waveform and the harmonic distortion decreases; on the other hand, as the number of levels increases, the construction cost of inverter gets higher. To fix this problem, in [12], a method is proposed, by use of which it is possible to employ less number of input supplies while more levels can be generated and hence harmonic declines.

In [13], the authors have used non-equal DC power supplies in a multilevel inverter to remove some harmonics, in other words, they have attempted to produce a more sinusoidal waveform by use of different amplitude supplies and as a result reduced the harmonic. Generally, exact algorithms can precisely find the optimal solution, but they do not work for the hard optimization problems such as, solving nonlinear problems to find switching angles; in such cases, another algorithms, whose solutions are not precise but can determine satisfying solutions and are called heuristic algorithms, can be used. Therefore, heuristic algorithms are a set of solutions which can solve the problems with any arbitrary number of levels. Some heuristic algorithms are as follows:

- Genetic Algorithm
- Particle Swarm Optimization (PSO)
- Bacterial Foraging Algorithm
- Ant Colony

In [14], genetic algorithm is used to find the switching angles to reduce the total harmonic distortion in multilevel inverters; in [15], genetic algorithm is also utilized to decrease the total harmonic distortion in the line voltage of a 7-levels inverter. In [16], the writers have proposed a technique, in which genetic algorithm is employed to find switching angles to eliminate the high order harmonics, and this technique is able to produce step voltage waveforms in a wide range of modulation coefficient. Nevertheless, even though genetic algorithm is generally a simple method and can be employed to more equations, it only focuses to minimize harmonics, is not fast and is not powerful enough to appropriately reduce the harmonics. Another method to find switching angles is PSO algorithm which is fairly fast, has great ability to converge and as much as possible, minimizes harmonics. The only deficiency of this method is that, this method, such as the preceding one, just concentrates on minimizing the harmonics [7].

In this paper a new algorithm, called Cuckoo algorithm, is employed to reduce total harmonic distortion in a 7-levels inverter. This method owns fast convergence speed over than the other ones.

2. INVERTER WITH SERIES H BRIDGE INVERTER OR SEPARATE DC SUPPLY

These kinds of inverters are constructed by the series combination of full-bridge inverters and separate DC supplies. Their output waveform, therefore, is the summation of waveforms generated by each full-bridge inverter. Such structure has some advantageous for this

kind of inverter. These inverters have cascade form and they can be easily conveyed and also adding new stages to them can be readily done. Furthermore, these inverters have simple structure and, in comparison with the two other common inverters, use lower equipment to generate a similar waveform. The general function of the H-bridge multilevel inverter is similar to the two other kinds of inverters, i.e. clamped diode multilevel inverter and flow capacitor multilevel inverter [17]. Fig.1 illustrates the structure of the H-bridge series inverter [18].

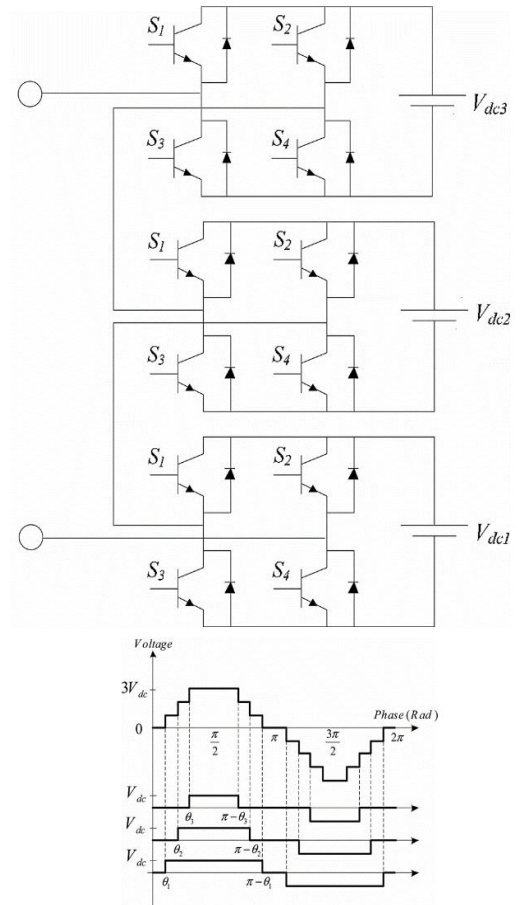

Figure 1: Structure of series H-bridge inverter: (7-levels inverter with its output waveforms)

3. HARMONICS

The distortions of voltage and current waveforms, whose frequencies are integer multiples of fundamental frequency, are called harmonic. Different switching strategies have been offered to make the output voltage quality better and reduce harmonics. In this paper a method, namely, minimizing total harmonic distortion (MTHD) of output voltage of an inverter, is used to reduce harmonic in a 7-levels inverter. In this method, for each stage of multilevel inverter an angle, so-called switching angle, is allocated. By virtue of this strategy, these angles can be computed in such a way that total harmonic content decreases. The switching angles ought to be calculated in such a manner that 1) voltage amplitude of the

fundamental frequency be obtained and 2) simultaneously, as much as possible, total harmonic content declined.

Fig.1 illustrates the phase voltage cycle of a 7-levels inverter whose Fourier series can be written as follows:

$$V_{phase}(\omega t) = \sum_{n=1}^{\infty} V_n \sin(n\omega t) \quad \dots(1)$$

By solving the equation (1) Fourier series analysis is obtained:

$$V_n = \begin{cases} \frac{2\sqrt{3}V_{dc}}{n\pi} (\cos(n\theta_1) + \cos(n\theta_2) + \cos(n\theta_3)) & \text{for odd } n \\ 0 & \text{for even } n \end{cases} \quad \dots(2)$$

The maximum value of equation (2) is obtained when all switching angles equal to zero:

$$V_1(\max) = \frac{6\sqrt{2}}{\pi} V_{dc} \quad \dots(3)$$

Where the normalized value of equation (2) is achieved by the following formula:

$$V_n^{pu} = \frac{V_n}{V_1(\max)} = \frac{1}{3n} ((\cos(n\alpha_1) + \cos(n\alpha_2) + \cos(n\alpha_3))) \quad \dots(4)$$

Now the RMS value is calculated for the fig. 1:

$$V_{rms} = \sqrt{\frac{2}{\pi} \left(\int_0^{\frac{\pi}{2}} v^2 d\omega t \right)} = V_{dc} \sqrt{\frac{2}{\pi} ((\alpha_2 - \alpha_1) + 4(\alpha_3 - \alpha_2) + 9(\frac{\pi}{2} - \alpha_3))} \quad \dots(5)$$

The normalized value of the preceding equation is as follows:

$$V_{rms}^{pu} = \frac{V_{rms}}{V_1(\max)} = \sqrt{\frac{\pi}{36} ((\theta_2 - \theta_1) + 4(\theta_3 - \theta_2) + 9(\frac{\pi}{2} - \theta_3))} \quad \dots(6)$$

In this case a new index, called modulation index, is defined as follows:

$$M = \frac{V_1}{12V_{dc} / \pi} \quad (0 \leq M \leq 1) \quad \dots(7)$$

In this equation M, regarding different values of V1, is defined in the interval [0, 1]. Where the THD value of phase voltage, using formulation presented in [1], is calculated by the next formula:

$$THD = \frac{\sqrt{\sum_{n=1}^{\infty} V_n^2}}{V_1} = \sqrt{\left(\frac{v}{V_1}\right)^2 - 1} \quad \dots(8)$$

By replacing the equivalent values of V1 and V2, obtained by Forier analysis in the above equation, we have:

$$THD = \sqrt{\left(\frac{\pi}{4} \frac{[(\alpha_2 - \alpha_1) + 4(\alpha_3 - \alpha_2) + 9(\frac{\pi}{2} - \alpha_3)]}{(\cos \alpha_1 + \cos \alpha_2 + \cos \alpha_3)^2} - 1\right)} \quad \dots(9)$$

Where $\alpha_1, \alpha_2,$ and α_3 are respectively switch angles which form a 7-levels inverter [18].

In this step, the objective function is determined to minimize the THD and set fundamental component:

Objective function:

$$\text{Min} \{ |V_1^* - V_1^{pu}| + THD \} \quad \dots(10)$$

Where V_1^* is the desired voltage for the fundamental component and V1 as expressed in the following, is obtained by setting n=1 in equation 4.

$$V_1^{pu} = \frac{1}{3} ((\cos(n\alpha_1) + \cos(n\alpha_2) + \cos(n\alpha_3))) \quad \dots(11)$$

$|V_1^* - V_1^{pu}|$ in the objective function is the penalty value. This is due to the fact that if the objective function contains only THD, and when the THD value becomes very small, V1 may recede from the desired value and this is unpleasant.

4. CUCKOO ALGORITHM

The optimization Cuckoo algorithm is a new global conscious method which is inspired from the life of a bird, named cuckoo. Similar to the other evolutionary algorithms, it begins with a initial population which consists of cuckoos' population. This population of cuckoos has some eggs which will be put in the nest of some host birds. Those eggs which greatly resemble to the host bird's eggs, have more chance to grow and turn into a mature cuckoo. The rest of the eggs are identified by the host bird and destroyed. The amount of the grown eggs shows the suitability of the nest of that area. As the number of the eggs, which can live in a zone and survive, be more, further profit (tendency) is assigned to that zone. Therefore, the place in which most number of eggs remains alive will be the parameter which COA tends to optimize. The cuckoos seek a place to maximize the survival of eggs [17].

5. SOLVING THE PROBLEM BY USE OF CUCKOO ALGORITHM

Here, the method of minimization total harmonic distortion (MTHD) value of inverter output voltage, which was previously presented, is used. Then, by replacing the mentioned equations and constraints of that section in the cuckoo algorithm, we find expected solutions, which are discussed in the following. In the Cuckoo algorithm some parameters should be set which are presented in table 1:

Cuckoo program for the 7-levels inverter is presented in [17]. Cuckoo algorithm for different modulation coefficients (which is in the last line of the appendix program A of [17], is shown by M) from the initial value 0.1 and step size 0.1 till final value 1 is run and the values of $\alpha_1, \alpha_2, \alpha_3$ are calculated. The results are shown in table 2.

6. RESULTS AND DISCUSSION

In order to validate the obtained results, they are compared with reference [18] which is published in one of the most authentic IEEE journals in 2012. As shown in table 3, Cuckoo algorithm by selecting different angles in comparison with the aforementioned reference could

improve the THD value in modulation coefficient 0.8 which corroborates the correctness of the results and the algorithm performance.

Table 1: Important parameters to adjust cuckoo algorithm in this paper

Maximum repeat	50	initial number of cuckoos	20
Number of cluster	2	Minimum number of egg-laying of each cuckoo	4
Maximum number of cuckoos in a region	10	Maximum number of egg-laying of each cuckoo	8

Table 2: Obtained results of Cuckoo algorithm for different modulation coefficients in a 7-levels inverter

Modulation coefficient	V_1^{pu}	$ V_1^* - V_1^{pu} \%$	α_1	α_2	α_3	%THD
0.1	0.100126	0.012551	72.52	90	90	128.67
0.20	0.200095	0.009464	53.11	90	90	63.50
0.30	0.300082	0.008187	25.81	90	90	29.27
0.40	0.400071	0.007073	19.25	75.16	90	31.12
0.50	0.500097	0.009726	16.22	57.31	90	21.57
0.60	0.60001	0.000981	11.59	36.92	88.8	17.55
0.70	0.700024	0.002422	11.16	35.22	72.42	17.04
0.8	0.800037	0.00369	9.74	30.06	56.7	12.28
0.9	0.900033	0.003281	7.2	21.91	38.72	14.77
1	0.994386	0.561368	1.77	5.33	8.9	37.95

Table 3: Comparison between cuckoo algorithm and reference [18] performance to reduce THD

Modulation coefficient	comparison	α_1	α_2	α_3	THD	V_1^{pu}
0.8	cuckoo	9.74	30.06	56.7	12.28	0.800037
	Reference [18]	11.50	28.71	57.10	12.54	0.80005

7. CONCLUSION

As illustrated, in this paper a new method to find the firing angles in multilevel voltage supply inverter to reduce the total harmonic distortion (THD) has been presented and the results validated. The theoretical and simulation results for 7-levels inverter, show the high applicability of the offered algorithm to identify appropriate firing angles to reduce low order harmonics and produce waveform with extremely small total harmonic distortion and similarity to sinusoidal waveform. In this strategy, in addition to aim to decline THD, the

fundamental component is positioned in a predetermined value with a great precision. This shows the high capability of algorithm to solve complicated algebraic equations.

REFERENCES

- [1] Q. Song and W. Liu, "Control of a cascade STATCOM with star configuration under unbalanced conditions," IEEE Trans. Power Electron., vol. 24, no. 1, pp. 45-58, Jan. 2009.
- [2] N. Flourentzou, V. G. Agelidis, and G. D. Demetriades, "VSC-based HVDC power transmission systems: An overview," IEEE Trans. Power Electron., vol. 24, no. 3, pp. 592-602, Mar. 2009.
- [3] M. Hagiwara, K. Nishimura, and H. Akagi, "A medium-voltage motor drive with a modular multilevel PWM inverter," IEEE Trans. Power Electron., vol. 25, no. 7, pp. 1786-1799, Jul. 2010.
- [4] M. T. Hagh, H. Taghizadeh, and K. Razi, "Harmonic minimization in multilevel inverters using modified species-based particle swarm optimization," IEEE Trans. Power Electron., vol. 24, no. 10, pp. 2259-2267, Oct. 2009.
- [5] W. Fei, X. Du, and B. Wu, "A generalized half-wave symmetry SHE-PWM formulation for multilevel voltage inverters," IEEE Trans. Ind. Electron., vol. 57, no. 9, pp. 3030-3038, Sep. 2010.
- [6] Anand, Aniket, and K. P. Singh. "Selective Harmonics Elimination of PWM Cascaded Multilevel Inverter." Aniket Anand et al./International Journal of Engineering Science and Technology (IJEST) 4.06 (2012): 2743-2748.

- [7] Z. Du, L. M. Tolbert, and J. N. Chiasson, "Active harmonic elimination for multilevel converters," IEEE Trans. Power Electron., vol. 21, no. 2, pp. 459-469, Mar. 2006.
- [8] M. G. Hosseini-Aghdam, S. H. Fathi, and G. B. Gharehpetian, "Elimination of harmonics in a multilevel inverter with unequal DC supplies using the homotopy algorithm," in Proc. IEEE Int. Symp. Ind. Electron., Jun. 4-7, 2007, pp. 578-583.
- [9] Chung-Ming Young; Sheng-Feng Wu, "Selective harmonic elimination in multilevel inverter with zig-zag connection transformers," Power Electronics, IET , vol.7, no.4, pp.876,885, April 2014
- [10] NiknamKumle, A.; Fathi, S.H.; Yazdi, S.S.H., "A novel memetic algorithm approach for selective harmonic elimination in multilevel inverters," Power Electronics, Drive Systems and Technologies Conference (PEDSTC), 2014 5th , vol., no., pp.205,210, 5-6 Feb. 2014
- [11] Karnik, N.; Singla, D.; Sharma, P.R., "Comparative analysis of harmonic reduction in multilevel inverter," Power India Conference, 2012 IEEE Fifth , vol., no., pp.1,5, 19-22 Dec. 2012
- [12] S. TasoujiHassanpour, A. Arjhangmehr, E. Mostafapour," THD Minimization in Cascade Multilevel Inverters with a Few DC Supplies and Optimum Voltage Levels", International Journal of Control Science and Engineering 2013.
- [13] M.Balachandran, P.Senthilkumar, N.P.Subramaniam, "Cascaded H-Bridge Multilevel Inverter Using Embedded Controller", International Journal of Communications and Engineering, 2012.
- [14] N. Farokhnia ; S.H. Fathi ; N. Yousefpoor ; M.K. Bakhshizadeh, "Minimisation of total harmonic distortion in a cascaded multilevel inverter by regulating voltages of DC supplies", IET Power Electronics, Volume 5, Issue 1, January 2012, p. 106 – 114.
- [15] Yousefpoor, N.; Fathi, S.H.; Farokhnia, N.; Abyaneh, H.A., "THD Minimization Applied Directly on the Line-to-Line Voltage of Multilevel Inverters," Industrial Electronics, IEEE Transactions on , vol.59, no.1, pp.373,380, Jan. 2012.
- [16] N. Farokhnia, S.H. Fathi, R. Salehi, G.B. Gharehpetian, M. Ehsani, "Improved selective harmonic elimination pulse-width modulation strategy in multilevel inverters", IET Power Electronics, 2012.
- [17] Mahmoud Enayati, "reduction of total harmonic content in 7-levels inverter using cuckoo algorithm", MSc seminar, Azad University of Bandar Abbas, June 2014.
- [18] Kavousi, A.; Vahidi, B.; Salehi, R.; Bakhshizadeh, M.; Farokhnia, N.; Fathi, S.S., "Application of the Bee Algorithm for Selective Harmonic Elimination Strategy in Multilevel Inverters," Power Electronics, IEEE Transactions on , vol.27, no.4, pp.1689,1696, April 2012.

AUTHORS PROFILE



interests include multilevel inverters, power electronics and electrical drives

Mahmoud Enayati was born in Hamedan, Iran, in 1985. He received his B.Sc from Azad University of Hamedan, Iran, in 2010. received his M.Sc in Electrical Engineering from Science and Research (Bandar abbas), Tehran, Iran in 2015. His research



interests include operations, reliability, planning and economics of electric energy systems

Sirius Mohammadi was born in Iran in 1978. He received his B.Sc., M.Sc. and Ph.D. Degrees in Electrical Engineering, in 2000, 2003 and 2013, respectively. He is currently an Assistant Professor in the Electrical Engineering Department, University of Azad. His research