

Human Battery for Indian Defence Force

T. Manochandar

Asst. Professor,
Department of ECE
manochandar@engineer.com

D. Siva Selvan

Final Year Student, Department of ECE,
V.R.S College of Engineering &
Technology, Affiliated to ANNA
University, Villupuram-607 107, India
sivaselvan220@gmail.com

S. Sudharsan

Final Year Student, Department of ECE,
V.R.S College of Engineering &
Technology, Affiliated to ANNA
University, Villupuram-607 107, India
sudharsan.s.91@gmail.com

Abstract - The Peltier effect can also be reversed and used to generate power in conditions where there are differences in temperature. All of these established scientific facts can be used to produce power from any thing where there are two different sources of temperatures. With the help of Inverse Peltier effect, Zigbee smart wearable physiological parameters monitoring device has been developed and reported in this paper. The system can be used to monitor physiological parameters, such as temperature, pressure and heart rate, of a human subject. Using several sensors to measure different vital signs, the person is wirelessly monitored. For achieving this, the power produced by using the human body heat and the Peltier effect will be stored in a capacitor acting as a battery and when required this power can be used for communication and other purposes also.

Keywords — Peltier Module, Body Temperature Measurement, Heart Rate Measurement, Military Monitoring, Sensors, Wireless Transmission, Zigbee.

I. INTRODUCTION

In modern science world, wireless sensors have become a great interest to research, scientific and technological community [3]. Though sensor networks have been opened up a new application which is useful to our Indian Defence Force.

“The Peltier effect is a temperature difference created by applying a voltage between two electrodes connected to a sample of semiconductor material” [1]. It is the important technique which is used to make the human battery. There arises a need for remotely monitoring the bio-parameters of the soldiers. The places include far away Warfield or camps wherein a soldier at any time can be monitored by the doctors at their place [4], [5]. At all such places there require a hassle free transmission system that can relay the soldier’s parameters from one place to another. Further in order to obtain the exact location of the person there is Zigbee module that tracks the location [3].

The project aims at designing a system that can acquire the soldier’s parameters and transmit it to the monitoring place. The Project consists of the biomedical parameter, Zigbee and display system. The biomedical parameters taken for this project include temperature, pressure and heart beat rate sensor. Suitable sensors are used for obtaining these parameters from the patients. The microcontroller present at the soldier’s side gets signals for the sensors. These parameters are given to the Zigbee transmitter continuously for transmission [3]. Suitable coding scheme is used for continuous data transmission. At the monitoring station a Zigbee receiver gets the parameters sends the parameters to PC which separates all

the parameters and displays in the format that the user required. Further the single receiver placed at the PC can receive signals from multiple patients and it work on CSMA/CD technology which is a collision free wireless transmission from multiple patients [3].

The microcontroller used has in build ADC and it can transmit data at a much faster rate for communication. Thus from a remote place a patients biomedical parameters can be monitored. Further any parameters can be easily monitored from the remote place such as fall detection, breathing sensor, etc. We propose the construction of one such device particularly useful to the Indian defence forces that are mostly operating in conditions where there are low temperatures, and generally it is also difficult to take conventional electricity to these places as well. In this project a versatile power source will be developed using which many applications will be possible [1], including telemetry of soldiers in a battle field, monitoring their vital parameters using the power produced by the heat from their body.

II. DESCRIPTION

Soldiers are being monitored using wireless sensors networks. Yet at the same time they know there is a high risk of injury or even death due to injury and loss of blood. Such people need to be monitored continuously and provided with immediate medical help and attention when required [6]. We seek to come up with solutions, which help to help the soldiers in Warfield. A system to monitor the bio-logical parameters of Human in Warfield, who need constant care, has been reported in. As a result, the monitoring unit has to be low-cost, efficient, accurate and non-invasive system.

This system has been designed with sensors, Zigbee repeaters and a PCuser. And further consists of a microcontroller, and a low-power transceiver. It records health parameters for 24 hours. These data are transmitted to the microcontroller and it passes it to the Zigbee transceiver. The Zigbee repeaters, which are installed, send the recorded data, including the repeater’s ID, to the PCuser. The ID is used to find out the Soldier’s location in the Warfield. The PCuser stores the received data, which can be used to analyze the Soldier’s overall health condition [9].

These show an increasing demand for health monitoring system which is affordable and continuous [7]. It not only allows the user to closely monitor changes in her or his physiological parameters but also provides feedback to help maintain an optimal health status [3].

III. SYSTEM OVERVIEW

Humans are warm blooded and as long as they are alive the body remains hot. Hence by using the human body heat as one source of temperature and the surrounding climate as another source of temperature, we can generate power using the Inverse Peltier effect.

The functional block diagram of Inverse Peltier effect is shown in Fig.1 which is used to produce power for this vital parameters measuring instrument. The passage of an electric current through the junction of two dissimilar conductors cools or heats the junction depending on the direction of the current. The modern Peltier junction is made out of semiconductor material. In the Peltier Module supplied in this Kit, 100's p-n junctions are connected electrically in series but thermally in parallel. The p- & n-doped elements are soldered to copper connecting strips. Ceramic faceplates electrically insulate these connecting strips from external surfaces. Bismuth telluride is the semiconductor material used.

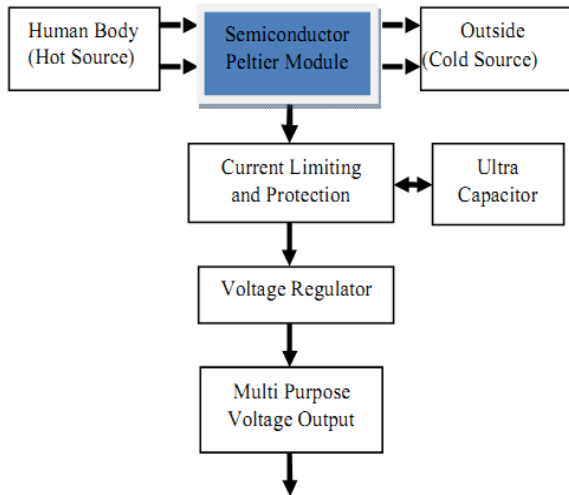

Fig.1. Functional Block Diagram of Inverse Peltier Effect

When a current is passed through the module a water drop placed on one side will boil or freeze depending on the direction of the current, pass the current the other way & the opposite surfaces will heat & cool It is important to understand that a Peltier Module is not a heat sponge which absorbs heat. It is a heat pump[1]. This effect is fully reversible; when the heat or cold is applied to both the sides of Peltier module it will produce voltages. It is then passed to the current limiting and protection circuit were it is limited and send to ultra capacitor. The function of the Ultra Capacitor is used to store the current generated by the Peltier module for temporary storage purpose. The Peltier module used in the system is shown below in Fig.2. And the performance specification of the Inverse Peltier Module is given in Table.1 below.

Later the generated power is fed to the voltage regulator. The LM317 series of adjustable 3-terminal positive voltage regulators is capable of supplying in excess of 1.5A over a 1.2V to 37V output range. They are exceptionally easy to use and require only two external resistors to set the output voltage. Also, the LM317 is packaged in standard transistor packages which are easily

mounted and handled. In addition to higher performance than fixed regulators, the LM317 series offers full overload protection available only in IC's. All overload protection circuitry remains fully functional even if the adjustment terminal is disconnected. During this recovery period, several bio-logical parameters need to be continuously monitored. Hence, telemedicine and remote monitoring of soldiers at Warfield are gaining added importance and urgency. Fig. 3 shows the functional block diagram of the system hardware.

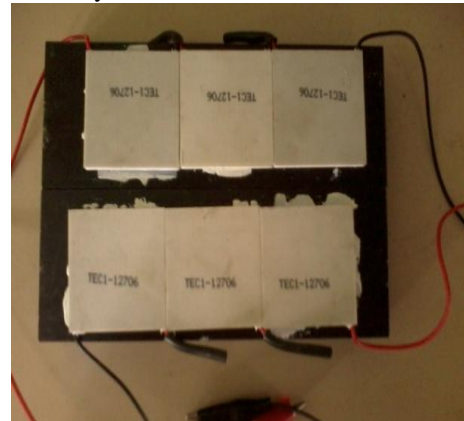
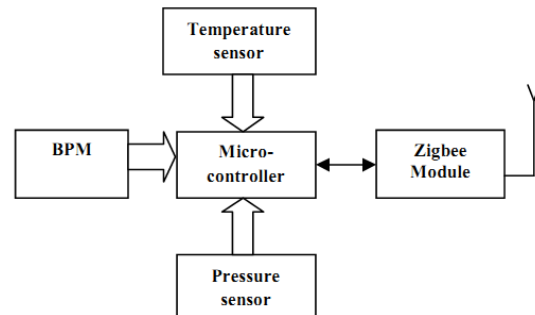

Fig.2. Peltier Module used in the system

Table 1: Performance specification of Inverse Peltier Module

Hot Side Temperature (° C)	25° C	50° C
Qmax (Watts)	50	57
Delta Tmax (° C)	66	75
I _{max} (Amps)	6.4	6.4
V _{max} (Volts)	14.4	16.4
Module Resistance (Ohms)	1.98	2.30

a) Transmitter side:



b) Receiver side:

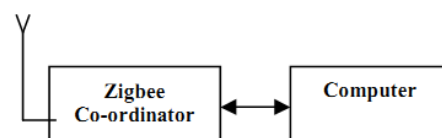

Fig.3. Functional block diagram of system hardware.

The system has been designed to take several inputs to measure bio-logical parameters of human such as temperature, heart rate and pressure. The inputs from the sensors are integrated and processed through the microcontroller. And the results are sent through the Zigbee Module to the PCuser, which display the result. When the receiver unit is connected to the PCuser the data results is updated automatically.

The hardware blocks are explained in full details in a later section.

IV. DETAILS OF THE SENSING SYSTEM

The sensor is a device that measures a physical quantity and converts it into a signal which can be read by an absorber or by an instrument. The system consists of three sensors: a temperature sensor, heart rate sensor, and a pressure sensor. Sensor circuitry used in the design generates analog voltage which is fed to the ADC (Analog-to-Digital) inputs of the PIC microcontroller. The description of individual sensors follows.

A. Temperature Sensor

The body temperature is noted down by the LM35 an integrated circuit temperature sensor whose output voltage is linearly proportional to the Celsius (Centigrade) temperature. The LM35 thus has an advantage over linear temperature sensors calibrated in ° Kelvin. The LM35 produces an analog output depending on the measured temperature. This measured temperature has to be measured by the PIC microcontroller using a 10 bit Analog-to-Digital converter (ADC) up to 30 external channels.

Fig. 4 shows the LM35, which is used as temperature sensor given below. LM35 sensor is mounted within the human body, allowing it to measure the external temperature of the human body. The body temperature is measured from the skin of the human body. There can be different methods to estimate the exact body temperature from skin temperature, measured from the body skin. Rather, relative changes are monitored, which sets off the alarm. The device is allowed to detect the changes in body temperature such as injury, heart attack, stroke and heat exhaustion. It has very low self-heating. The LM35 is rated to operate over a -55° to +150°C temperature range.

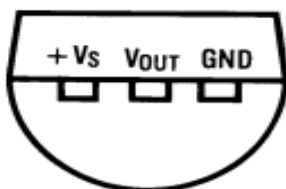

Fig.4. Temperature sensor LM35

B. Heart Rate Sensor

A simple heart rate sensor has developed to measure the patient's beats per minute (bpm). It is a portable heart rate monitoring system. HRM 2115 is the heart beat sensor which has been used in this project. The operating input voltage is 3.3V. The heart beat rate sensor output is in the form of square wave in the range between 0-5V. The sensors consist of IR module coupled with semiconductor

chip. The IR involves by measuring the blood volume at the wavelength of 700-900 nm. At this particular wavelength most tissues do not absorb light other than haemoglobin [3].

The heart rate sensor is available in two different options for user convenient. The 'E' version is for using the sensor by clipping to the ear lobe. The 'B' version is for using it with the finger. Any of these can be used dependent on user convenience and suitability. To get the best and most accurate results the heart rate sensor is mounted in the finger ring

The sensor unit consists of an infrared light-emitting-diode (IR LED) and a photodiode, placed side by side. Fig. 5 shows the functional block diagram of the heart rate sensor. To measure the heart rate by sensing the change in blood volume in a finger artery while the heart is pumping the blood. It consists of an infrared LED that transmits an IR signal through the fingertip of the subject, a part of which is reflected by the blood cells. The reflected signal is detected by a photo diode sensor. The changing blood volume with heartbeat results in a train of pulses at the output of the photo diode, the magnitude of which is too small to be detected directly by a microcontroller. Therefore, a two-stage high gain, active low pass filter is designed using two Operational Amplifiers (OpAmps) to filter and amplify the signal to appropriate voltage level so that the pulses can be counted by a microcontroller. For further processing the output pulses is directly fed into the PIC microcontroller through its digital port. The Heart rate sensor used in this project is shown below in Fig.6.

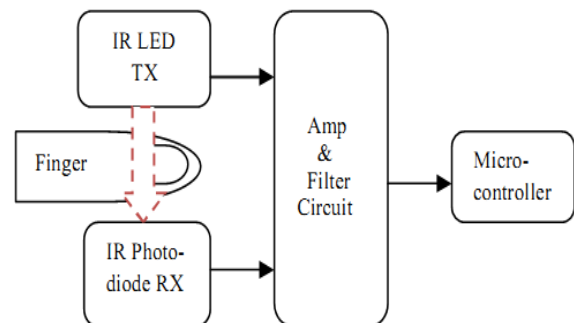

Fig.5. Functional block diagram of the heart rate sensor.



Fig.6. HRM2115 Heart Beat Rate sensor.

The PIC microcontroller was fed by temperature sensor, heart rate and pressure sensor through cable connection. The PIC microcontroller was mounted onto a separate PCB which also had the Zigbee module connection.

The heart rate is measured by using the microcontroller.

C. Pressure Sensor

The MPX5010/MPXV5010G series piezoresistive transducers are state of art of the monolithic silicon pressure sensors designed for a wide range of applications, but particularly those employing a microcontroller or microprocessor with A/D inputs. This transducer combines advanced micromachining techniques, thin-film metallization, and bipolar processing to provide an accurate, high level analog output signal that is proportional to the applied pressure [2]. The Integrate sensors with microcontrollers and communication technologies, patient monitoring, respiratory devices, and drug-delivery systems, fully automating to the point of providing 24/7 information. Patients could possibly have increased mobility due to the smaller size of the devices and therefore not be required to be hospitalized during treatments, keeping the cost of healthcare down.

The signal from the pressure sensors is measured as well as like the heart rate signal. It is used to detect sharp impact, when the soldier gets injury and he goes to anaesthetics, to be ignored. The purpose of this sensor was to detect sudden changes in the blood that could indicate the soldier needs an emergency.

V. MICROCONTROLLER AND UART INTERFACING AND COMMUNICATION

The microcontroller used in this unit is the PIC 18LF45K22. For the operation of the above mentioned tasks the PIC microcontroller is programmed using “C” language in this project. The inputs are provided from the sensors in the form of analog and digital voltages. A dedicated channel is provided for every sensor, ADC for temperature sensor, digital port0 for heart rate and impact sensor which is multiplexed by the microcontroller.

A. Communication

Communication is provided between the system and the receiver unit is wireless. The data measured by the sensors is done through a network between the sensors and computer receiving and storing the values. For the wireless communication Zigbee modules-Tarang modules were used, which is powered from the Inverse Peltier module and transmitted under the unlicensed 2.4 GHz frequency band [2]. It works at 3.3V DC. The RF output power is 1mW. The Tarang module is UART compatible and hence can be connected to a microcontroller or a PC.

- Range: Indoor/Urban: up to 100' (30 m)
- Outdoor line-of-sight: up to 300' (100 m)

The main reason for the chosen of this microcontroller was because of its low-power consumption and it has a extendable instruction set for programming. It is powered by an Inverse Peltier effect, and ports use 3.3 V, from where sensor and Zigbee transmitter are powered. Fig. 7 shows the connection overview of sensors, wirelessly.

B. Zigbee Module

The module we used in this project is Tarang module. These modules provide an easy to configure network, with a high data rate up to 250 kbps. They work at 3.3V and can be connected to the PIC 18LF45K22 without any additional power-supply circuit.

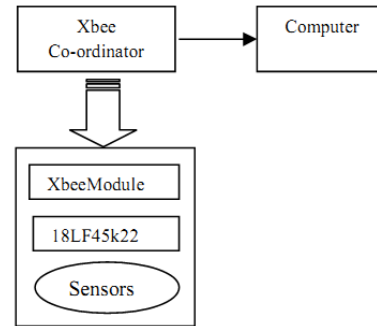

Fig.7. System overview for wireless communication.

Tarang modules are designed with low to medium transmit power and for high reliability wireless networks. The modules require minimal power and provide reliable delivery of data between devices. The interfaces provided with the module help to directly fit into many industrial applications. The modules operate within the ISM 2.4-2.4835 GHz frequency band with IEEE 802.15.4 baseband. They establish the communication automatically because they come in a preconfigured mode.

To connect the ZigBee Tarang module to the PIC Microcontroller is done by providing the Power-Supply (3.3 V), Ground and TX and RX of the Microcontroller are connected to VCC, GND, DIN and DOUT of the Zigbee module (Fig. 8) [3]. Zigbee Receiver is also Tarang module only which operate at 3.3V but it requires a UART Interface which is compatible to connect with PC/Laptop.

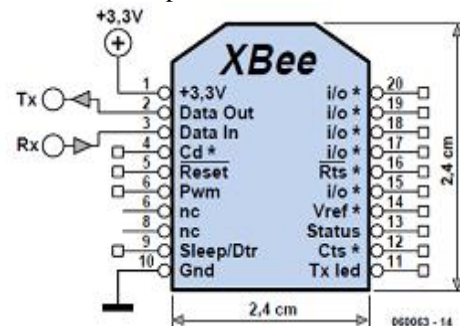

Fig.8. Zigbee module electrical connection with microcontroller.

C. UART Interface

The USB (Universal Serial Bus) port of a computer is a general interface to which any external devices can be connected. The external devices can be conventional computer input output devices like keyboard, mouse, a printer, camera etc. Additionally other hardware like projects, embedded systems can also be connected to the USB port, for communication with various software on the computer.

But most microcontrollers and other embedded hardware have a conventional UART interface. But the USB port of a computer cannot be connected directly to the UART interface. Additionally any hardware connected to the USB port needs device drivers that have to be installed on the computer for the operating system to identify the external device and communicate with it accordingly.

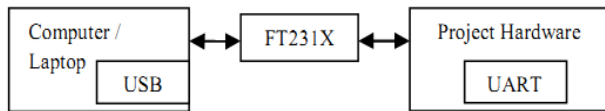

Fig.9. Functional block diagram of UART Interface

Hence there is a need for a device that can enable communication between the UART interface of an embedded system and the USB port of a computer. Various ICs are available that can perform this function. The FT231X is one such IC that can perform the function of UART to USB conversion.

The FT231X is a 20 pin IC that can work either with an external 5V power supply or it can even work with the power from the USB port of the computer. It is also capable of communicating with external devices that have either a 5V UART interface or a 3.3V UART interface. The device drivers needed by the computer for communicating with the FT231X IC are also provided by the manufacturers of the IC and hence there is no need for the user to develop the device drivers. For all of these reasons the FT231X is an ideal IC to use for connecting any project hardware to a PC or a laptop. Functional block diagram of UART Interface is shown above in Fig.9

VI. PROTOTYPE AND EXPERIMENTAL RESULTS

The Microcontroller board is designed and tested using MPLAB IDE. The Fig.10 shows the transmitting unit prototype which was powered by Inverse Peltier Module as shown in above Fig.2. Using Inverse Peltier Module which is used to generate power more than 24hours even if the soldier sleeping also due to cold temperature available outside and hot temperature taken from the human body.

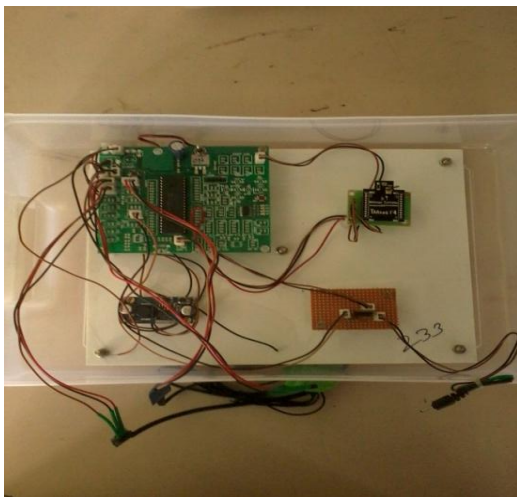
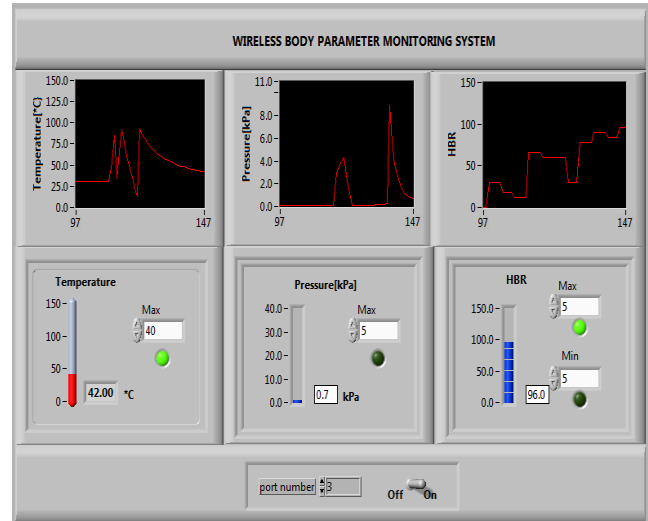

Fig.10. Transmitting unit prototype

The digital data of Temperature, pressure and heart beat rate is measured with help of sensors and displayed below in Fig.11.



VII. DISCUSSIONS AND CONCLUSIONS

In this paper, we have presented the research, to monitor physiological parameters such as temperature, heart rate, and body pressure.

Inverse Peltier Effect is used to generate the power from the body to provide the power supply for the device. With some modification, the system can be made available commercially. Future improvements will focus on the usage in smarter ways, so that it could be moulded around the wrist unit, making it more comfortable for the wearer.

The unit was initially designed for the soldiers but can initially use by the elderly, within the house measuring their health status.

ACKNOWLEDGMENT

The study is fully carried under the supervision of Mr. T. Manochandar Asst. Prof. Dept. of ECE, VRS College of Engg. & Tech. affiliated to Anna University, India and Ensemble technology, Chennai. We would like to thank them for their kind support in this research.

REFERENCES

- [1] Megawatt scale energy recovery in the Rankine cycle, *Jonathan Siviter*, Andrew Knox, James Buckle, Andrea Montecucco School of Engineering University of Glasgow Glasgow, UK, 2012.
- [2] "A design of a Band-Aid like health monitoring node for body sensor network", by Fangmin Sunl, Zhan Zhao\ Zhen Fang\ Yaohong Shil, Xianxiang Chenl, Yundong Xuanl, State Key Laboratory of Transducer Technology Institute of Electronics, Chinese Academy of Sciences Graduate University of Chinese Academy of Sciences Beijing, China
- [3] "A Zigbee-Based Wearable Physiological Parameters Monitoring System", by Karandeep Malhi, Subhas Chandra Mukhopadhyay, Fellow, IEEE, Julia Schnepfer, Mathias Haefke, and Hartmut Ewald.
- [4] Dittmar, F. Axisa, G. Delhomme, and C. Gehin, "New concepts and technologies in home care and ambulatory monitoring," *Studies in Health Technol. Inform.*, pp. 9-35, 2004.
- [5] A. Pantelopoulos and N. Bourbakis, "Design of the new prognosis wearable system-prototype for health monitoring of people at risk," in *Advances in Biomedical Sensing, Measurements, Instrumentation and Systems*, S. C. M

- ukhopadhyay and A. Lay-Ekuakille, Eds. : Springer-Verlag, 2010, vol. 55, Lecture Notes in Electrical Engineering, pp.29-42.
- [6] Computer Vision and Wireless Sensor Networks in Ambient Assisted Living: State of the Art and Challenges 1 Velislava Spasova, 2 Ivo Iliev Department of Electronics, Technical University of Sofia, Sofia, Bulgaria.
- [7] M. Scholtz, "Addressing the global demands for improved healthcare," in Proc. Telemedicine 21st Century, Opportunities Citizens, Society, Industry , 1999, pp. 11-18.
- [8] A. Gaddam, S. C. Mukhopadhyay, and G. Sengupta, "Smart home for elderly using optimized number of wireless sensors," in Advances in Wireless Sensors and Sensors Network . : Springer-Verlag, 2010, vol. 64, Lecture Notes in Electrical Engineering, pp. 307-328.
- [9] E. Jovanov, D. Raskovic, J. Price, J. Chapman, A. Moore, and A. Krish-namurthy, "Patient monitoring using personal area networks of wire-less intelligent sensors," Biomed. Sci. Instrum., pp. 373-378, 2001.

AUTHOR'S PROFILE



Manochandar Thenralmanoharan

was born in Tamilnadu, India in 1988. He received B.E. in Electronics and Communication Engineering from Kamban Engineering College (A constituent college of Anna University, Chennai) in 2009 and M.E. in Communication Systems from Prathyusha Institute of Technology and Management, Tiruvallur (A constituent college of Anna University, Chennai) in 2012. He is interested in the fields of Wireless Communication, Neural Networks, Image Processing and Embedded Systems. He is Assistant Professor of Electronics and Communication Engineering in VRS college of Engineering and Technology, Arasur (A constituent college of Anna University, Chennai).



Siva Selvan

was born in Parikkal, Tamilnadu, India on September 15, 1991. Then, he moved with his family to Villupuram, Tamilnadu, India, where he finished his school in 2009 and he is currently pursuing his Final year Bachelor of Engineering degree in electronics and communication in V.R.S College of Engineering and Technology (Affiliated to Anna University), Villupuram, India.

His interests include biomedical engineering and embedded systems. Mr. Selvan is the member of the Indian Society for Technical Education.



Sudharsan Srinivasan

was born in Tamilnadu, India in 1991. He is pursuing B.E. in Electronics and Communication Engineering from V.R.S.College of Engineering and technology (A constituent college of Anna University, Chennai) in 2013. He is interested in the fields of Digital Electronics and Embedded Systems.